

PIN	∅2.0	∅2.5	
-----	------	------	--

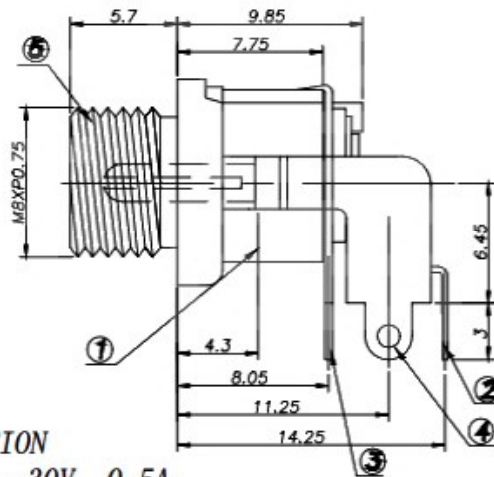
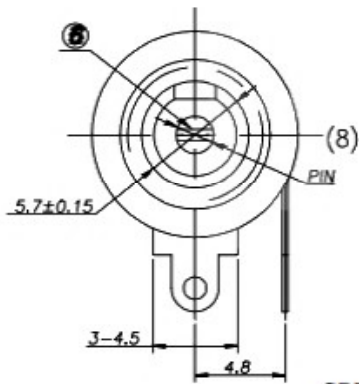
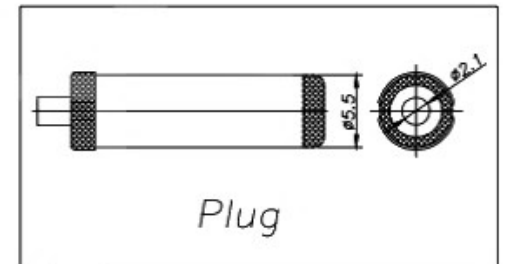
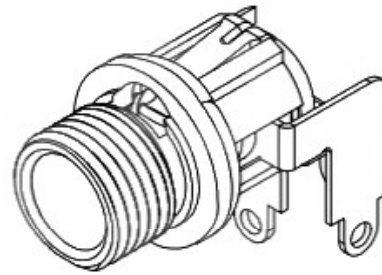

SPECIFICATION

1. Rated Load : 30V 0.5A;
2. Contact resistance: $\leq 30m\Omega$;
3. Insulation resistance: $\geq 100M\Omega$;
4. Withstand voltage: AC500V ;
5. Insertion and extraction force: 3-30N;
6. life test: 5,000 cycles.

⑧	Nut	1	H59	Ni-Plating
⑦	Washer	1	SPCC	Ni-Plating
⑥	Pin (∅2.0)	1	Phosphor bronze	Ni-Plating
⑤	Bushing	1	Brass	Ni-Plating
④	Shunt Terminal	3	Phosphor bronze	Cu-Sn-Plating
③	Tip Spring	1	Phosphor bronze	Cu-Sn-Plating
②	Center pin terminal	1	Brass	Cu-Sn-Plating
①	Housing	1	PBT	Black
NO.	DESCRIPTION	QTY	MATERIAL	PLATING

DONG GUAN XI BANG ELECTRONIC CO., LTD

COPYRIGHT RESERVED,PLEASE DO NOT COPY.

PART NAME		DC POWER JACK		DRAWING	Y,C,ZHANG	DWG.No.	SBICL
PART NO.				CHECK	G.C.Chen	REV.	A1
UNIT :	mm	TOLERANCE	UP TO 5	±0.2	APPROVAL	DATE	
		OTHERWISE	ABOVE 5~30	±0.3			
			ABOVE 30	±0.5	SCALE	2:1	PAGE
			ANGLE	±3'			1 OF 1