

**SPECIFICATIONS**

1. ELECTRICAL CHARACTERISTICS:
  - 1-1.RATING: DC 5A 12V
  - 1-2.CONTACT RESISTANCE: 30mΩ MAX(INITAL)
  - 1-3.DIELECTRIC WITHSTANDING VOLTAGE: 500V AC FOR ONE MINUTE
  - 1-4.INSULATION RESISTANCE: 100MΩ MIN, MEASURED BY 500V DC
2. MECHANICAL PERFORMANCE
  - 2.1.INSERTION FORCE :0.3-3.0kgf
  - 2.2.WITHDRAWAL FORCE :0.3-3.0kgf
3. LIFE TEST
  - 3.1.3-1.ELECTRONICS LIFE TEST 5,000 CYCLES.

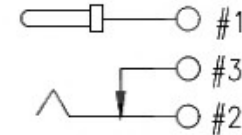

CIRCUIT

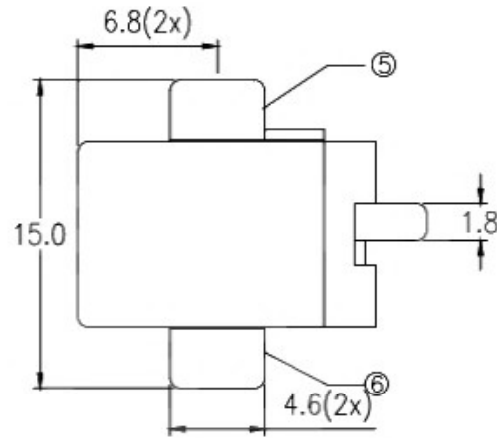
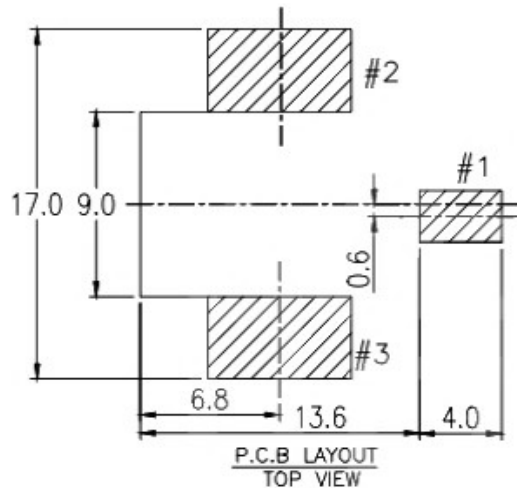
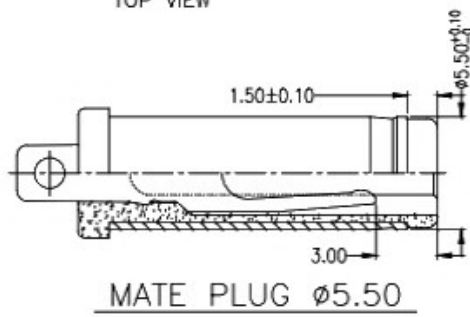

6	TERMINAL #2	C5210-H	1	20u"Ag PLATED OVER 50u" Ni
5	TERMINAL #3	C2680-H	1	20u"Ag PLATED OVER 50u" Ni
4	TERMINAL #1	C2680-H	1	20u"Ag PLATED OVER 50u" Ni
3	PIN	C3604	1	50u" Ni PLATED
2	COVER	PA9T UL94-V0	1	BLACK
1	HOUSING	PA9T UL94-V0	1	BLACK
NO.	PARTS	MATERIAL	QTY.	FINISHING

DONG GUAN XI BANG ELECTRONIC CO., LTD

COPYRIGHT RESERVED,PLEASE DO NOT COPY.

PART NAME	DC POWER JACK		DRAWING	Y.C.Zhang	DWG.No.	Robin
PART NO.			CHECK	G.C.Chen	REV.	A0
UNIT :	TOLERANCE	XX ± 0.3	ANGLE	APPROVAL	DATE	
mm	OTHERWISE	X,XX ± 0.2	φ±Δ	SCALE	PAGE	1 OF 1
		X,XXX ± 0.1		1:1		