

HIGH TEMP. MARK FOR PA-9T
(SQUARE 0.7x0.7 DEPTH 0.25mm)

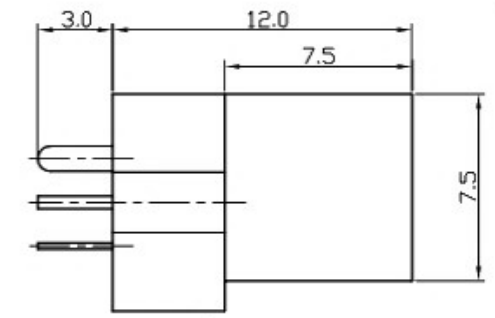

CAVITY MARK RAISED 0.1mm
(ON THE OUTSIDE OF APPEARANCE)

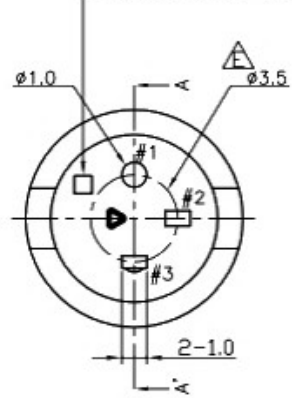
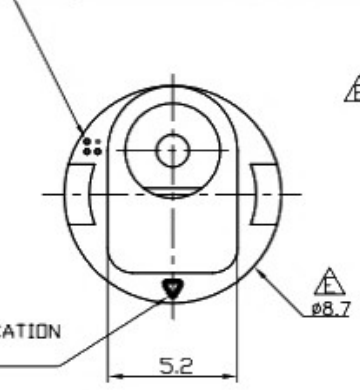

GREEN PRODUCT IDENTIFICATION
MARK-RAISED 0.05mm

SPECIFICATIONS:

- ELECTRICAL CHARACTERISTICS:
 - RATING: 12VDC MAX. 1A MAX.
 - CONTACT RESISTANCE: 20mΩ MAX.(INITIAL)
 - DIELECTRIC WITHSTANDING VOLTAGE: 200V DC FOR ONE MINUTE.
 - INSULATION RESISTANCE: 10MΩ MIN. MEASURED BY 250 VDC
- MECHANICAL CHARACTERISTICS:
 - INSERTION FORCE : 3.0 KGF MAX.
 - WITHDRAWAL FORCE : 0.3~1.5 KGF
- LIFE TEST: 5,000 CYCLES MIN.
- OTHER GENERAL SPEC. TO REFER "2DC-0036 SERIES SPEC".
- TO CONFORM TO SINGATRON HAZARDOUS SUBSTANCE FREE SPEC.
- GREEN PRODUCT IDENTIFICATION MARK ON JACK:
- GREEN PRODUCT IDENTIFICATION LABEL ON PACKAGING: **G.P. PASS**
- FOR REFLOW SOLDERING LEAD-FREE PROCESS.
- PACKAGING: BAG

B-B' SECTION
SCALE 50:1

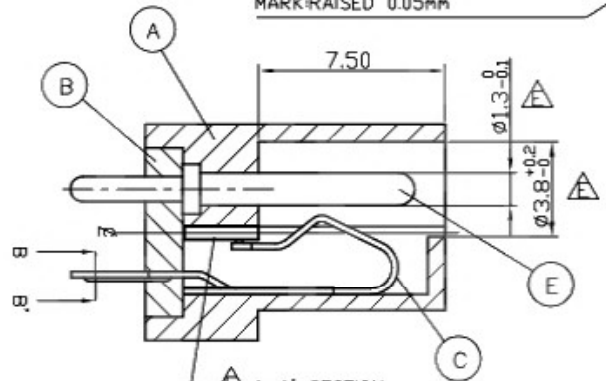

A-A' SECTION
SCALE 5:1

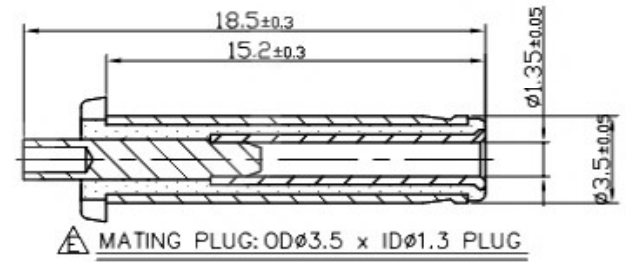
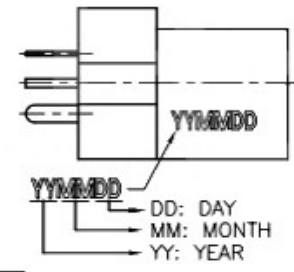

MATING PLUG: ODφ3.5 x IDφ1.3 PLUG

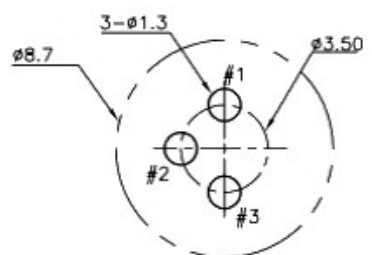

RECOMMENDED P.C.B LAYOUT
TOP VIEW Tolerance: ±0.05

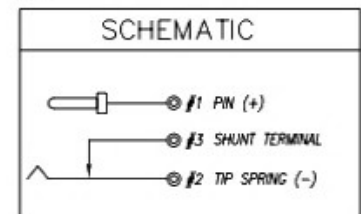

NO	DESCRIPTION	QTY	MATERIAL	PLATING & COLOR
E	CONTACT PIN	1	BRASS	GOLD FLASH
D	SHUNT TERMINAL	1	BRAS 0.5t	GOLD FLASH
C	TIP SPRING	1	COPPER ALLOY 0.25t	GOLD FLASH
B	COVER	1	PA9T UL 94V-0	BLACK COLOR
A	BODY	1	PA9T UL 94V-0	BLACK COLOR

DONG GUAN XI BANG ELECTRONIC CO., LTD

COPYRIGHT RESERVED, PLEASE DO NOT COPY.

PART NAME		DC POWER JACK		DRAWING	Y.C,ZHANG	DWG.No.	SBICL
PART NO.				CHECK	G.C.Chen	REV.	A1
UNIT :	TOLERANCE	UP TO 5	±0.2	ANGLE	APPROVAL	DATE	15-01-2008
mm	OTHERWISE	ABOVE 5 ~30	±0.3	0°±3	SCALE	PAGE	1 OF 1
		ABOVE 30	±0.5				
		ANGLE	±5				