

- SPECIFICATIONS:
- ELECTRICAL CHARACTERISTICS:
    - CURRENT RATING: 12V&1A MAX.
    - CONTACT RESISTANCE: 50mOHMS MAX.
    - DIELECTRIC VOLTAGE WITHSTAND :500V AC FOR ONE MINUTE
    - INSULATION RESISTANCE:100MOHMS MIN. MEASURED BY 500V DC
  - MECHANICAL CHARACTERISTICS:
    - INSERTION FORCE:3~30N
    - WITHDRAWAL FORCE:3~30N
  - LIFE TEST:5000 CYCLES
  - ENVIRONMENTAL:
    - OPERATING TEMPERATURE:-40°C~85°C
  - SALT SPRAY:24H AT 35°C WITH 5%-SALT-SOLUTION CONCENTRATION.
  - PACKAGE: TAPE&REEL

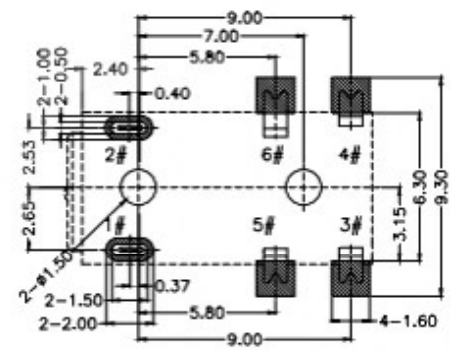

Recommended PCB Layout(TOP VIEW)  
(Tolerance:±0.05)

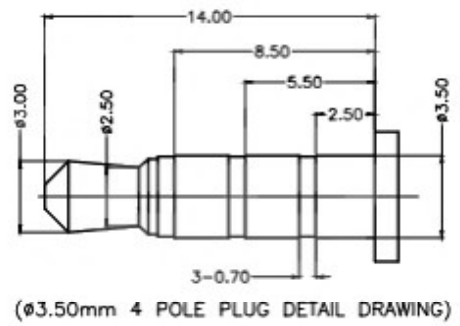
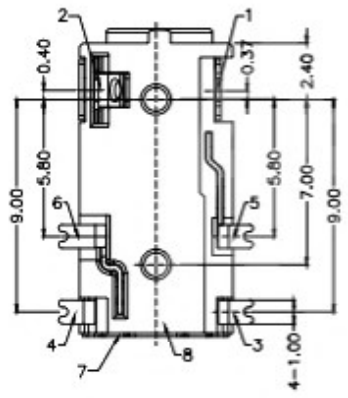
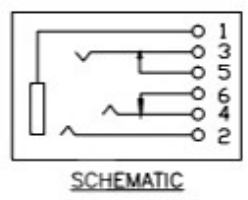
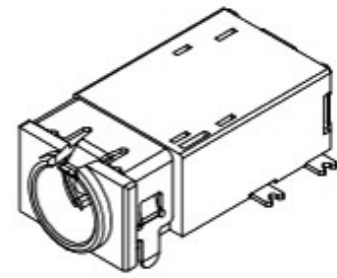

3D VIEW

⑥	HOUSING	1	PPA; COLOR BLACK	
⑦	COVER	1	SUS304; CLEANING	
⑥	CONTACT 6#	1	C5210; NICKEL UNDER PLATING OVERALL,GOLD PLATING ON OVERALL;	
⑤	CONTACT 5#	1	C5210; NICKEL UNDER PLATING OVERALL,GOLD PLATING ON OVERALL;	
④	CONTACT 4#	1	C5210; NICKEL UNDER PLATING OVERALL,GOLD PLATING ON OVERALL;	
③	CONTACT 3#	1	C5210; NICKEL UNDER PLATING OVERALL,GOLD PLATING ON OVERALL;	
②	CONTACT 2#	1	C5210; NICKEL UNDER PLATING OVERALL,GOLD PLATING ON OVERALL;	
①	CONTACT 1#	1	C5210; NICKEL UNDER PLATING OVERALL,GOLD PLATING ON OVERALL;	
ITEM	PART NAME	Q'TY	MATERIAL	REMARK

东莞市溪榜电子有限公司

COPYRIGHT RESERVED,PLEASE DO NOT COPY.

PART NAME		PHONE JACK		DRAWING		Y,C,ZHANG		DWG.No.		SBICL	
PART NO.		PJ-3136M-D		CHECK		G.C.Chen		REV.		A1	
UNIT :		TOLERANCE		UP TO 5		APPROVAL		DATE			
mm		OTHERWISE		ABOVE 5~30		SCALE		PAGE		1 OF 1	
				±0.2							
				±0.3							
				±0.5							
				±3							