

REV.	ECN. NO.	APPD.

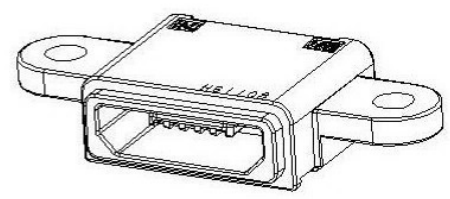
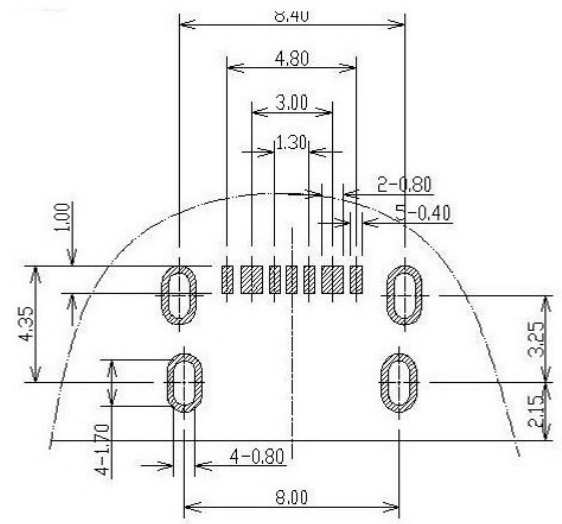
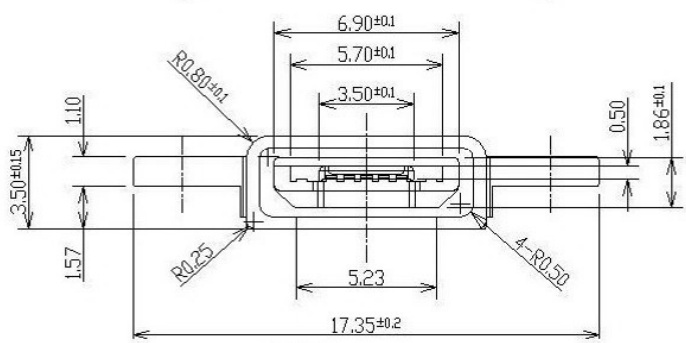
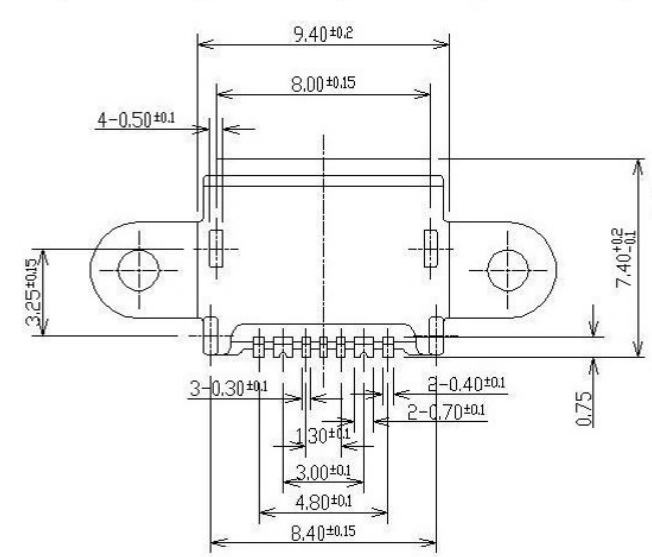
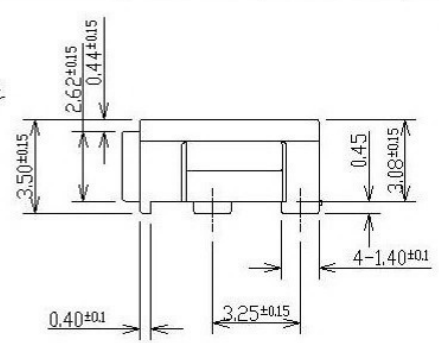
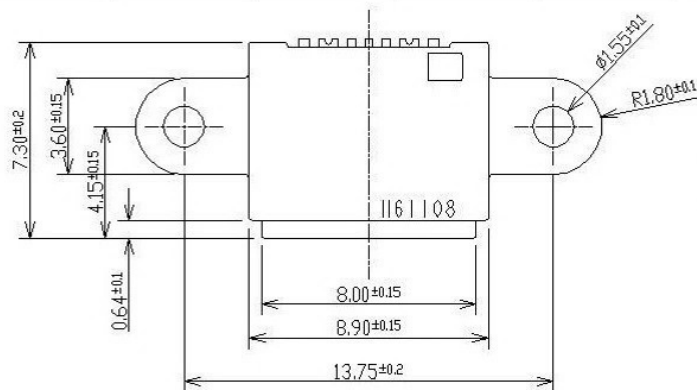

- NOTES:
SPECIFICATION:
1. CURRENT RATING: 3.0A MAX
 2. DIELECTRIC WITHSTAND VOLTAGE: 100VAC
 3. TEMPERATURE RANGE: -30 °C ~ 85 °C
 4. CONTACT RESISTANCE: 40 MILLIONHM MAX
 5. INSULATION RESISTANCE: 100 MEGOHMS MIN.
 6. INSERTION FORCE :8N~35N
 7. UNMATING FORCE: 8N~35N
 8. DURABILITY:1500 CYCLES

3	Shell	1	SUS 301 1/4H	
3	PLASTIC Shell	1	PA9T&LCP (G.F30%)	
2	Contact	4	BRASS C2680-EH Au/Ni Plating T=0.25mm	
1	Housing	1	PA10T (G.F30%)	
ITEM	PART NAME	Q'TY	FINISH	NOTE

X. ±0.50	X* ±2*	东莞市溪榜电子有限公司	PART NO.	TITLE: IP68
.X ±0.30	.X* ±1*			
.XXX ±0.05	.XX* ±0.5*			
THESE DRAWINGS AND SPECIFICATIONS ARE THE PROPERTY OF E-ZONE ELECTRONIC TECHNOLOGY CO.,LTD.AND SHALL NOT BE REPRODUCED, COPIED OR USED IN ANY MANNER WITHOUT THE PRIOR WRITTEN CONSENT OF E-ZONE ELECTRONIC TECHNOLOGY CO., LTD		FINISH	APPD: RADDM	DWG NO: USB MICROIPX7
		Q'TY	CHKD: MARK	SCALE SHEET REV. 1/1 1/2 A2
			DR: JANE CHOU 2019/07/11	