

SPECIFICATION
 Contact Rating: 50mA, 12V DC
 Contact Resistance: 100mΩ max
 Insulation Resistance: 100mΩ min.500V DC
 Dielectric Strength: 250V AC/1minute
 Travel: 0.25mm
 Operating Temp: -30°C~+85°C
 Storage Temp: -30°C~+80°C

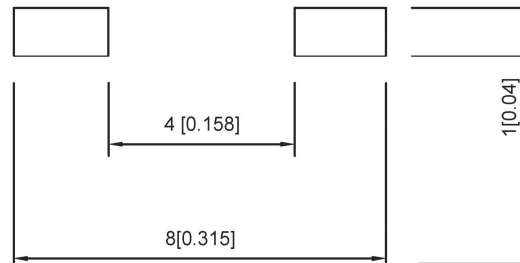
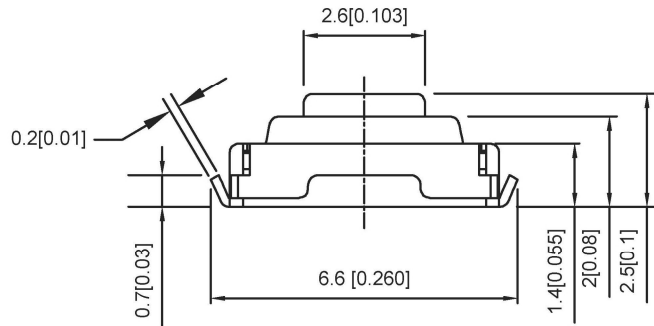

PAPT NO	TS-1101A-X-X
Operating Force	A:100gf B:160gf C:260gf
Height	H:2.5
color	B:black W:white R:Red

ITEM	PAPT NAMF	TER,NO	QTY	MATERIAL	FINISHING	REMARK
⑤	Terminal	—	2	Brass (0.30t)	Plating silvering	—
④	Contact	—	1	F.ag/Sus	Natural	—
③	Base	—	1	Lcp	—	—
②	Cover	—	1	Brass	Plating Nickel	—
①	Keystake	—	1	Pa46	—	—

MARK	DESCRIPTION	REVISIONS	DATE	REVISED	APPROVED	UNSPECIFIED TOLERANCES	DSND	DATE	SCALE: N/A	MODEL TYPE: TACT SWITCH
ΔX						units: mm	DWN	DATE	VIEW:	PART NO.:
ΔX						tolerance: X.X ±0.2mm	CHKD	DATE	UNIT: mm/in	DWG NO.:
ΔX						X.XX ±0.1mm	APPD	DATE	SIZE: A4	TS-1101A-X-X
MARK						X.XXX ±0.05mm	DONG GUAN XI BANG ELECTRONIC CO., LTD			WEIGHT 1.0g
www.alpsr.com www.gdxjdz.com www.xbswitch.com										SHEET 1/1
										REVISION A0