

SPECIFICATION

Contact Rating: 50mA, 12V DC
 Contact Resistance: 100mΩ max
 Insulation Resistance: 100mΩ min. 500V DC
 Dielectric Strength: 250V AC/1minute
 Travel: 0.25mm
 Operating Temp: -30°C ~ +85°C
 Storage Temp: -30°C ~ +80°C

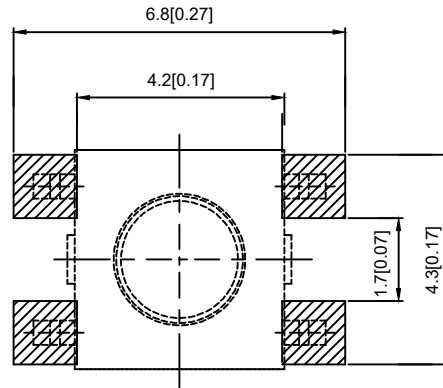
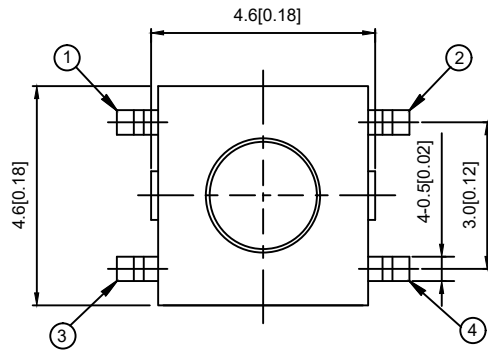

P.C.B LAND PATTERN

PAPT NO	TS-1127-X
Operating Force	A:100gf B:160gf C:260gf
Height	H:1.5

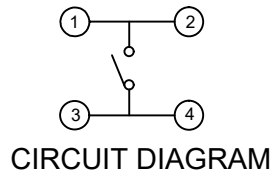

ITEM	PAPT NAMF	TER,NO	QTY	MATERIAL	FINISHING	REMARK
⑤	Terminal	—	4	Brass (0.30t)	Plating silvering	—
④	Contact	—	1	F.ag/Sus	Natural	—
③	Base	—	1	Pa46		—
②	Cover	—	1	Spcc	Plating Nickel	—
①	Keystake	—	1	Pa46		—

MARK	DESCRIPTION	DATE	REVISED	APPROVED	UNSPECIFIED TOLERANCES	DSND	DATE	SCALE: N/A	MODEL TYPE:		
ΔX					units: mm	DWN	DATE	VIEW:	TACT SWITCH		
ΔX					tolerance: X.X ±0.2mm	CHKD	DATE	UNIT: mm/in	PART NO.:		
ΔX					X.XX ±0.1mm	APPD	DATE	SIZE: A4	DWG NO.:		
MARK					X.XXX ±0.05mm				TS-1127-X		
REVISIONS						DONG GUAN XI BANG ELECTRONIC CO., LTD			WEIGHT	SHEET	REVISION
www.alpsr.com www.gdxjdz.com www.xbswitch.com									1.0g	1/1	A0