

P.C.B LAND DIMENSION

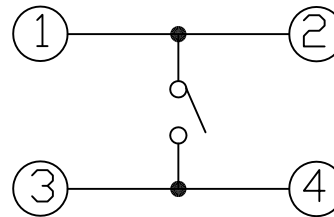
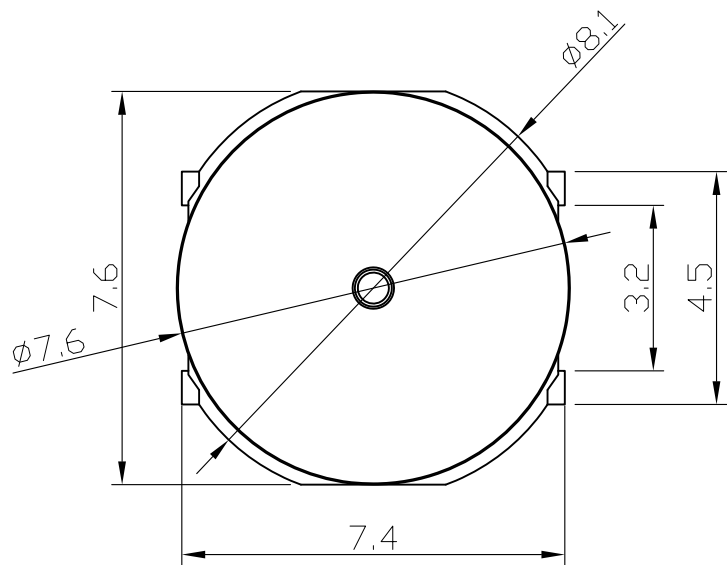
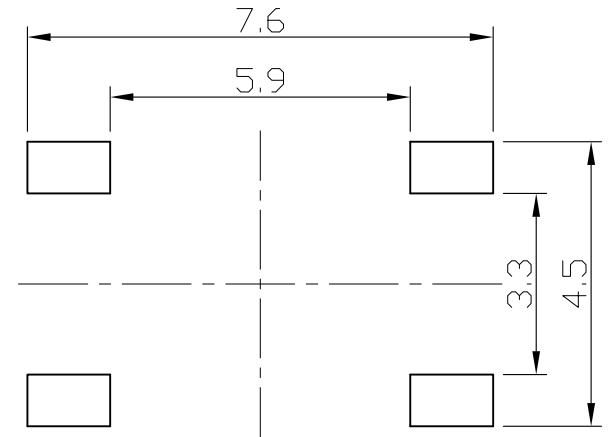

CIRCUIT DIAGRAM

SPECIFICATION

Contact Rating: 50mA, 12V DC  
 Contact Resistance: 100mΩ max  
 Insulation Resistance: 100mΩ min. 500V DC  
 Dielectric Strength: 250V AC/1minute

REFERENCE DRAWING

0.73 mm	WHITE	BALK	250±50gf	100,000 Cycles
"H"	STEM COLOR	BASE COLOR	O/FORCE	LIFE

DSND		DATE		SCALE: N/A	MODEL TYPE: TACT SWITCH		
DWN		DATE		VIEW:	PART NO.:		
CHKD		DATE		UNIT: mm	DWG NO.: TS-7476-C		
APPD		DATE		SIZE: A4			
DONG GUAN XI BANG ELECTRONIC CO., LTD					WEIGHT	SHEET	REVISION
					1.0g	1/1	A0

					units: mm
					tolerance:
Δx					X.X ±0.2mm
Δx					X.XX ±0.1mm
Δx					X.XXX ±0.05mm
MARK	DESCRIPTION	DATE	REVISED	APPROVED	UNSPECIFIED TOLERANCES
REVISIONS					
www.alpsr.com		www.gdxjdz.com		www.xbswitech.com	