

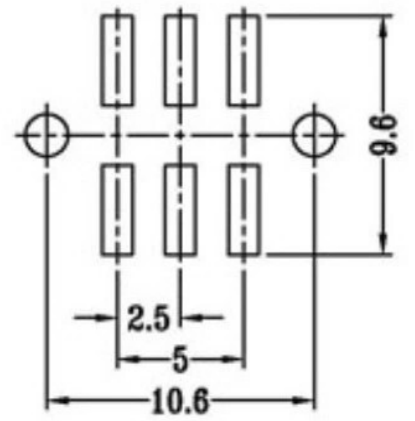

CAD FILE:

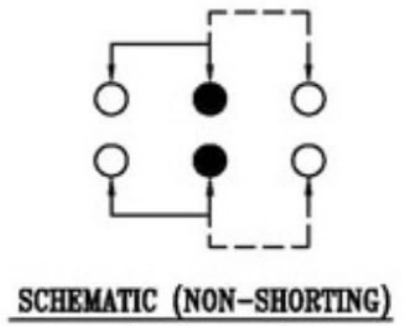

P.C.B LAYOUT
BOTTOM VIEW

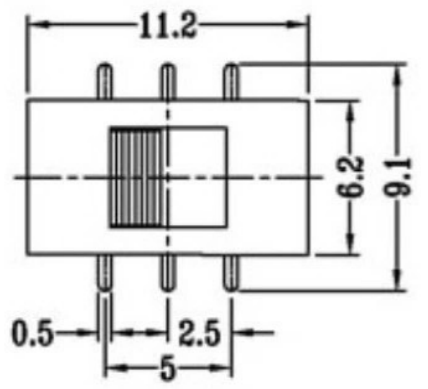
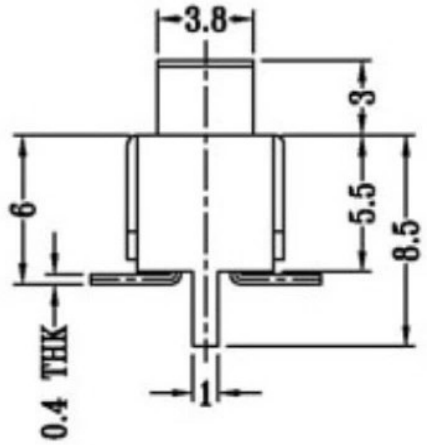
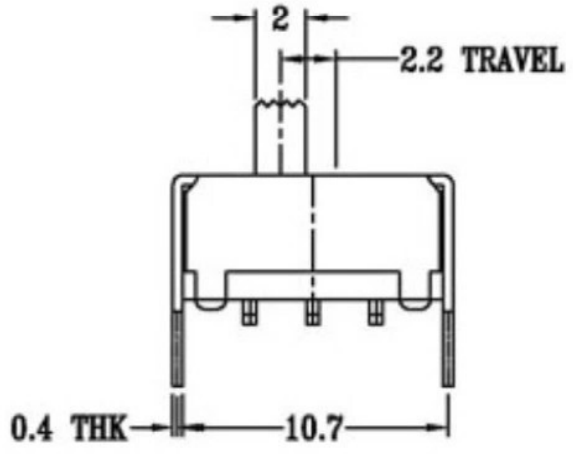

X=2-10
单位: mm

注: "*"表示关键尺寸(6个)

| NO. | PARTS | MATERIALS | Q'TY | FINISH | TOLERANCE | ISSUE | DATE | DESCRIPTIONS OF REVISION | APPD. |
|-----|--------------|----------------|------|-----------|-------------------------------|-------|------------|--------------------------|-----------------|
| 8 | | | | | UNLESS SPECIFIED | | | | |
| 7 | STEEL BALL | STEEL | 1 | NATURAL | | | | | |
| 6 | SPRING | STEEL WIRE | 1 | NATURAL | | | | | |
| 5 | CONTACT CLIP | PBS STRIP | 2 | Ag PLATED | WITHIN | A | 2012-10-26 | 初版 | |
| 4 | TERMINAL | BRASS STRIP | 8 | Ag PLATED | OVER | | | | |
| 3 | BASE | PHENOLIC RESIN | 1 | NATURAL | TITLE : VERTICAL SLIDE SWITCH | | | UNIT : mm | DRWG NO.: |
| 2 | FRAME | STEEL STRIP | 1 | Ni PLATED | MODEL: | | | SCALE: 3:1 | DWN. 2012-10-26 |
| 1 | KNOB | POM | 1 | BLACK | 东莞市溪榜电子有限公司 | | | CHK'D | 2012-10-26 |
| | | | | | | | | APPD. | |