

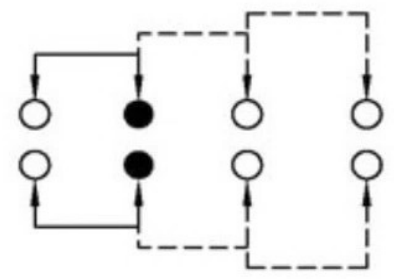

CAD FILE:

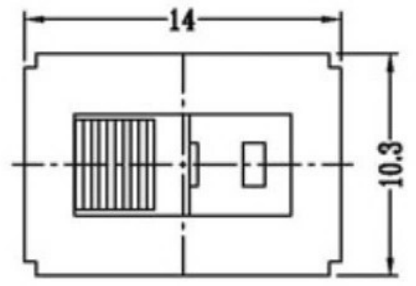

SCHMATIC (NON-SHORTING)

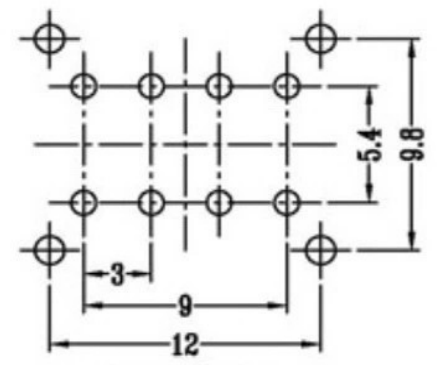

P.C.B LAYOUT
BOTTOM VIEW

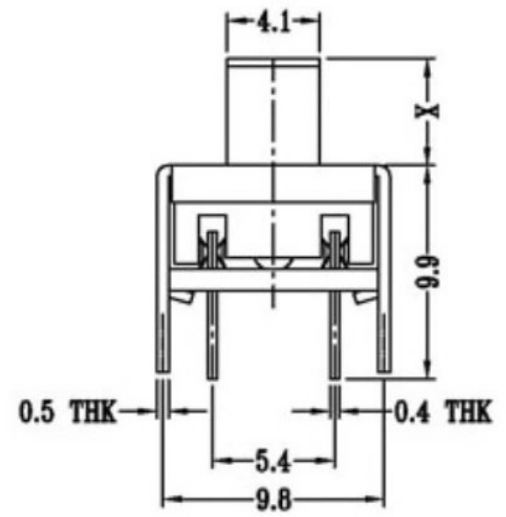
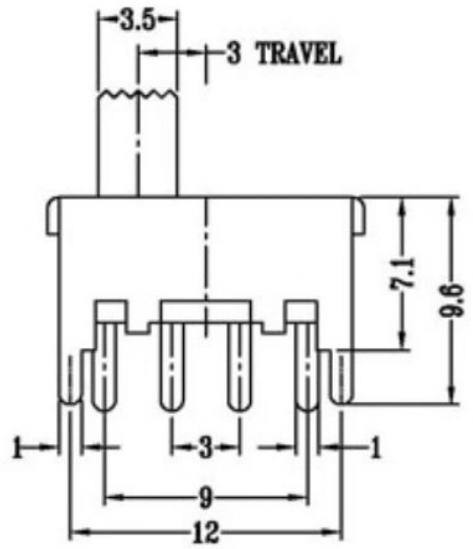

X=3-12
单位: mm

注: "*"表示关键尺寸(6个)

NO.	PARTS	MATERIALS	Q'TY	FINISH	TOLERANCE UNLESS SPECIFIED	ISSUE	DATE	DESCRIPTIONS OF REVISION	APPD.
8									
7	STEEL BALL	STEEL	1	NATURAL					
6	SPRING	STEEL WIRE	1	NATURAL		A	2012-10-26	初版	
5	CONTACT CLIP	PBS STRIP	2	Ag PLATED	WITHIN				
4	TERMINAL	BRASS STRIP	8	Ag PLATED	OVER				
3	BASE	PHENOLIC RESIN	1	NATURAL	TITLE : VERTICAL SLIDE SWITCH			UNIT : mm	DRWG NO.:
2	FRAME	STEEL STRIP	1	Ni PLATED	MODEL:			SCALE: 3:1	DWN. 2012-10-26
1	KNOB	POM	1	BLACK	东莞市溪榜电子有限公司			CHK'D	2012-10-26
								APPD.	