

加防水圈示意图

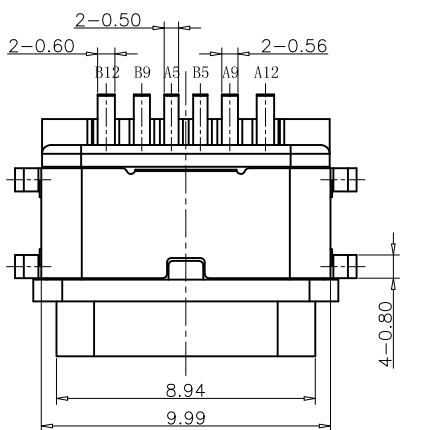

RECOMMEND P.C.B LAYOUT(COMPONENT SIDE)  
TOLERANCE FOR PCB LAYOUT IS ±0.05

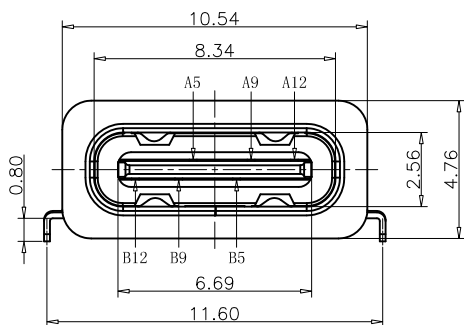
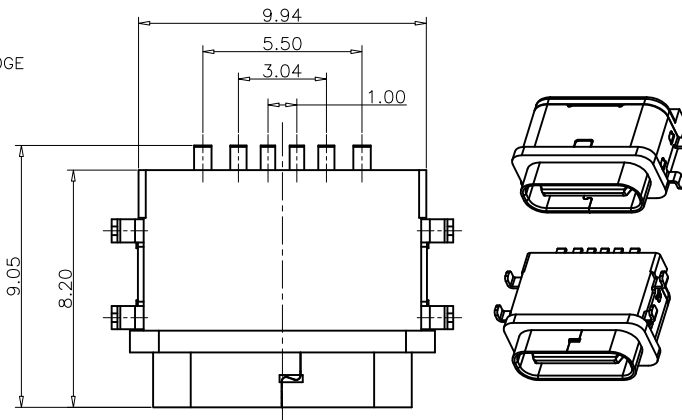
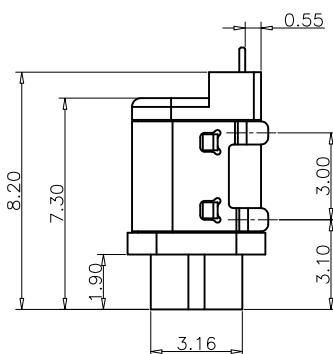

- NOTES:  
SPECIFICATION:  
1.CURRENT RATING: 3.0A MAX  
2.VOLTAGE: 100 VAC  
3.TEMPERATURE RANGE: -30°C~+85°C  
4.CONTACT RESISTANCE: 40 MILLIONHM MAX  
5.INSULATION RESISTANCE: 100 MEGOHMS MIN  
6.INSERTION FORCE: 5N~20N  
7.UNMATING FORCE: 8N~20N  
8.DURABILITY: 10000 CYCLES  
9.WATER PROOFNESS:THISPRODUCTIS BASED ON IPX7.

TABLE:

NO	PART	Q'TY	Material
1	SHELL	1	STAINLESS STEEL,NI PLATED
2	CONTACT	6	COPPER STEEL,TIN/Au/NI PLATED
3	MID PLATE	1	STAINLESS STEEL,NO PLATING
4	1MD HOUSING	1	HIGH TEMPERATURE RESISTANT PLASTIC BLACK UL94 V-0
5	2MD HOUSING	1	HIGH TEMPERATURE RESISTANT PLASTIC BLACK UL94 V-0
6	SHIELDING PLATE	1	STAINLESS STEEL,NI PLATED

PIN ASSIGNMENT:

PIN NO	A1&B12	A4&B9	A5	B5	A9&B4	A12&B1
SIGNAL NAME	GND	VBUS	CC1	CC2	VBUS	GND
PCB PAD NO.	C1	C2	C3	C4	C5	C6

东莞市溪榜电子有限公司  
DONG GUAN XIBANG ELECTRONICS CO., LTD.

TOLERANCE: X.XX ±0.30 X.XXX ±0.20 X.XXX ±0.10 X.X ±0.10 X.X ±0.05 X.X ±0.05 X.X ±0.05	DRAWN BY :	DATE :	PART NAME:	
		2015.08.18	TYPE-C 6P防水四脚沉板L8.2	
	CHECKED BY :	DATE :	PART NO.	SEE TABLE
	2015.08.18	MOLD NO.		
 UNIT: mm [inch] SCALE:1:1 SIZE: A4	APPROVED BY :	DATE :	DRAW NO:	
	2015.08.18	SHEET NO.	1 OF 1	