

防水圈图示

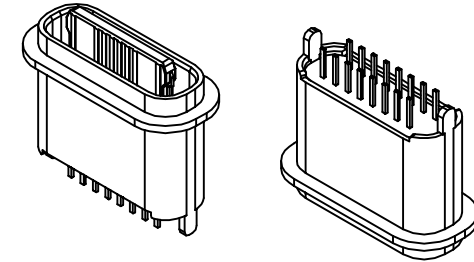

NOTES:

SPECIFICATION:

1. CURRENT RATING: 3.0 A
2. VOLTAGE RATING: 3.0 V
3. VBUS & GND PINS AND OTHER PINS: 40mΩ/PIN MAX  
SHIELD: 50mΩ/MAX  
LLCR MAX. CHANGE OF ALL PINS: 10Ωm
4. INSULATION RESISTANCE: 100MΩ MIN
5. DIELECTRIC WITHSTAND VOLTAGE, AC 100V FOR 1MIN
6. INSERTION FORCE: 0.5~2.0kgf
7. UNMATING FORCE: 0.8-2.0kgf
8. DURABILITY: 10000 CYCLES
9. OPERATING TEMPERATURE: -35°C~+85°C
10. THE PEAK TEMPERATURE ON THE BOARD SHALL BE MAINTAINED FOR 10 SECONDS AT 260°C
11. WATERPROOF: IP-X7.

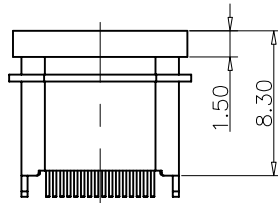
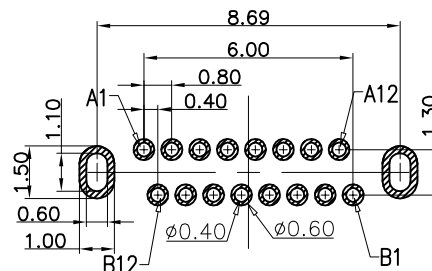
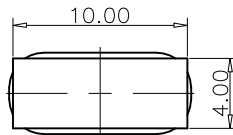
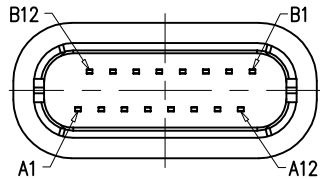
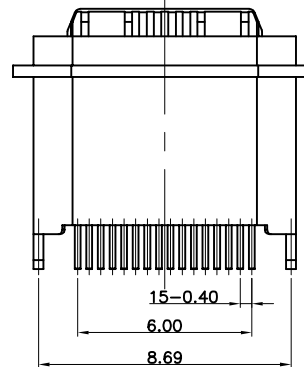
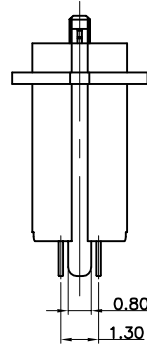
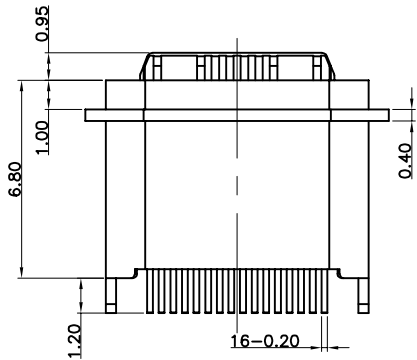

装前塞示意图

RECOMMEND P.C.B LAYOUT  
TOLERANCE UNSPECIFIED  $\pm 0.05\text{mm}$

USB TYPE C PIN ASSIGNMENTS

PIN NUMBER	SIGNAL NAME	PIN NUMBER	SIGNAL NAME
A1	GND	B12	GND
A4	VBUS	B9	VBUS
A5	CC1	B8	SBU2
A6	DP1	B7	DN2
A7	DN1	B6	DP2
A8	SBU1	B5	CC2
A9	VBUS	B4	VBUS
A12	GND	B1	GND

东莞市溪榜电子有限公司

DONG GUAN XIBANG ELECTRONICS CO., LTD.

TOLERANCE: X.XX ±0.30 X.XXX ±0.20 X.XXX ±0.10 X.X ±0.05 X.X ±0.02 X.X ±0.01	DRAWN BY :	DATE :	PART NAME: TYPE-C16P防水立插 H6.8粉末冶金舌头外露0.95	
		2015.08.18		
	CHECKED BY :	DATE :	PART NO.	SEE TABLE
		2015.08.18	MOLD NO.	
	APPROVED BY :	DATE :	DRAW NO.	
		2015.08.18	SHEET NO.	1 OF 1

UNIT: mm [inch]  
SCALE: 1:1 SIZE: A4