

NOTES:

SPECIFICATION:

1. CURRENT RATING: 3.0A MAX
2. DIELECTRIC WITHSTAND VOLTAGE: 100VAC
3. TEMPERATURE RANGE: -30 °C ~ 85 °C
4. CONTACT RESISTANCE: 40 MILLIONHM MAX
5. INSULATION RESISTANCE: 100 MEGOHMS MIN.
6. INSERTION FORCE : 5N~20N
7. UNMATING FORCE: 8N~20N
8. DURABILITY:10,000 CYCLES

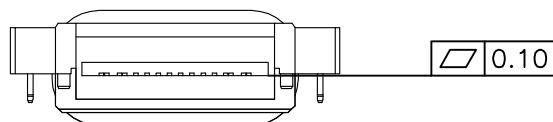
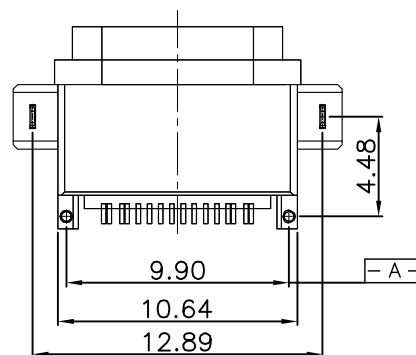
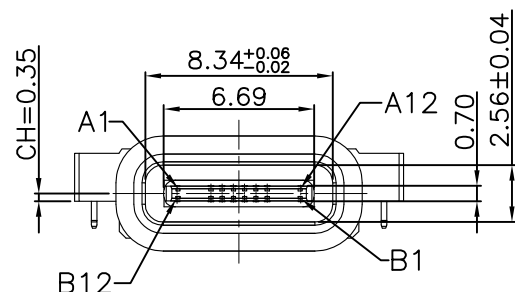

ITEM	PART NAME	Q' TY	FINISH	NOTE
3	Shell	1	PA9T (G.F30%)	
2	Contact	5	Phosphor bronze C5191R-EH Au/Ni Plating T=0.12mm	
1	Housing	1	LCP (G.F30%)	

东莞市溪榜电子有限公司
DONG GUAN XIBANG ELECTRONICS CO., LTD.

TOLERANCE: X.X ±0.30 X.XX ±0.20 X.XXX ±0.10 X.XX ±0.10 X.X ±0.05 X.X ±0.05	DRAWN BY :	DATE :	PART NAME:	
			2015.08.18	TYPE-C 16P防水两脚沉板L9.08
UNIT: mm [inch] SCALE:1:1 SIZE: A4	CHECKED BY :	DATE :	PART NO.	SEE TABLE
		2015.08.18	MOLD NO.	
	APPROVED BY :	DATE :	DRAW NO.	
		2015.08.18	SHEET NO.	1 OF 1

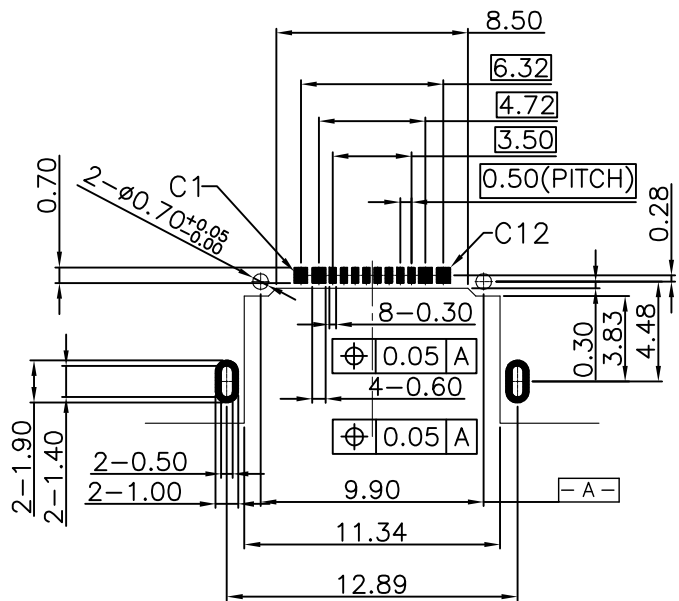

RECOMMENDED PCB LAYOUT(TOP VIEW)

THICKNESS T=1.0mm
DEFAULT TOLERANCE+/-0.05

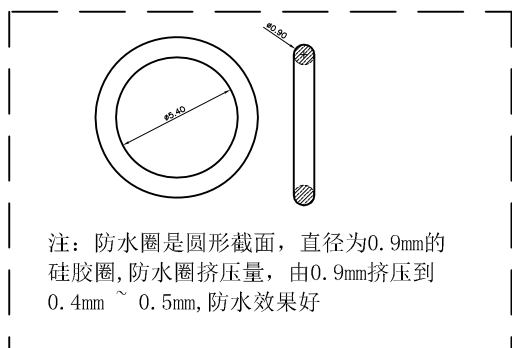

注：防水圈是圆形截面，直径为0.9mm的硅胶圈，防水圈挤压量，由0.9mm挤压到0.4mm ~ 0.5mm，防水效果好

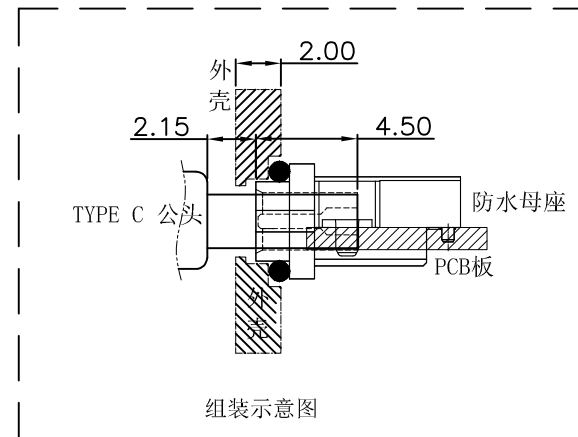

INTERFACE(FRONT VIEW)

A1	A2	A3	A4	A5	A6	A7	A8	A9	A10	A11	A12
GND			VBUS	CC1	DP1	DN1	SBU1	VBUS			GND
GND			VBUS	SBU2	DN2	DP2	CC2	VBUS			GND
B12	B11	B10	B9	B8	B7	B6	B5	B4	B3	B2	B1

PIN ASSIGNMENT

PIN NO.	A1&B12	A4&B9	B8	A5	B7	A6	A7	B6	A8	B5	A9&B4	A12&B1
SINGAL NAME	GND	VBUS	SBU2	CC1	DN2	DP1	DN1	DP2	SBU1	CC2	VBUS	GND
PCB PAD NO.	C1	C2	C3	C4	C5	C6	C7	C8	C9	C10	C11	C12



东莞市溪榜电子有限公司
DONG GUAN XI BANG ELECTRONICS CO., LTD.

TOLERANCE: X.X ±0.30 X.XX ±0.20 X.XXX ±0.10 X.XX ±0.10 X.X ±0.05 X.X ±0.05 X.X ±0.05	DRAWN BY :	DATE :	PART NAME:	
	CHECKED BY:	DATE :	PART NO.	SEE TABLE
	APPROVED BY:	DATE :	MOLD NO.	
UNIT: mm [inch] SCALE: 1:1 SIZE: A4			DRAW NO:	
			SHEET NO.	1 OF 1