

防止焊接时助焊剂进入开关内部
平行产品本体脚形简化自动化焊接工艺

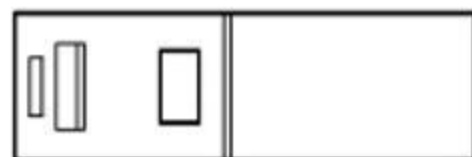

Rating	10.1A 125/250VAC	Mechanical Life	1,000,000 cycles
Contact Resistance	100mΩ Max	Electrical Life	10,000 cycles
Insulation Resistance	>100MΩ DC500V	Ambient Temper. Used	-25℃ to +125℃
Withstand Voltage	AC1500V 1min.	Ambient Humidity Used	≤85% at +40℃
Soldering Temper.	235±5℃ 5s	Operating Force	150±40gf

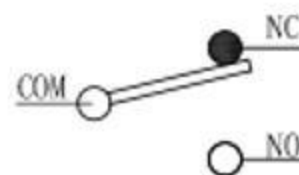
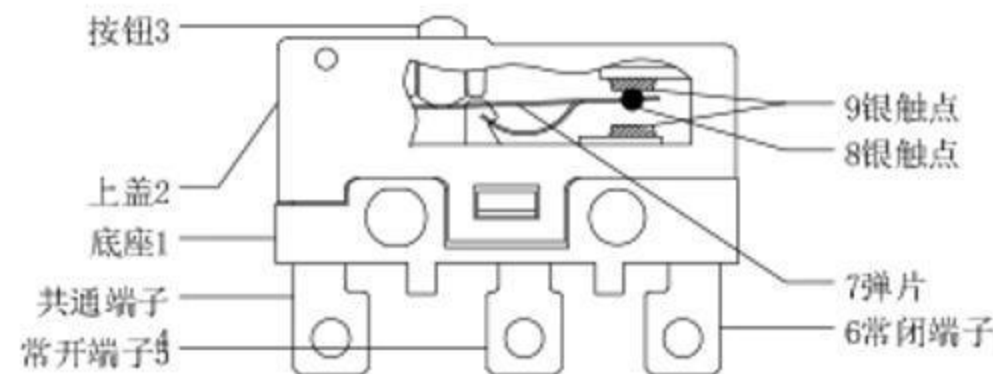
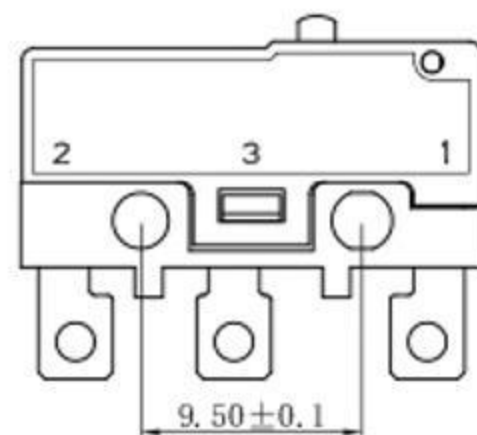
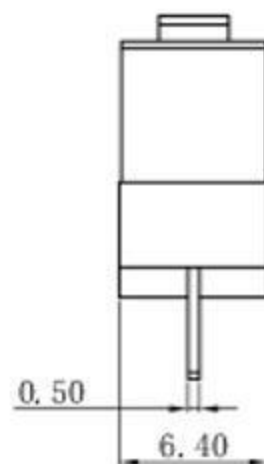
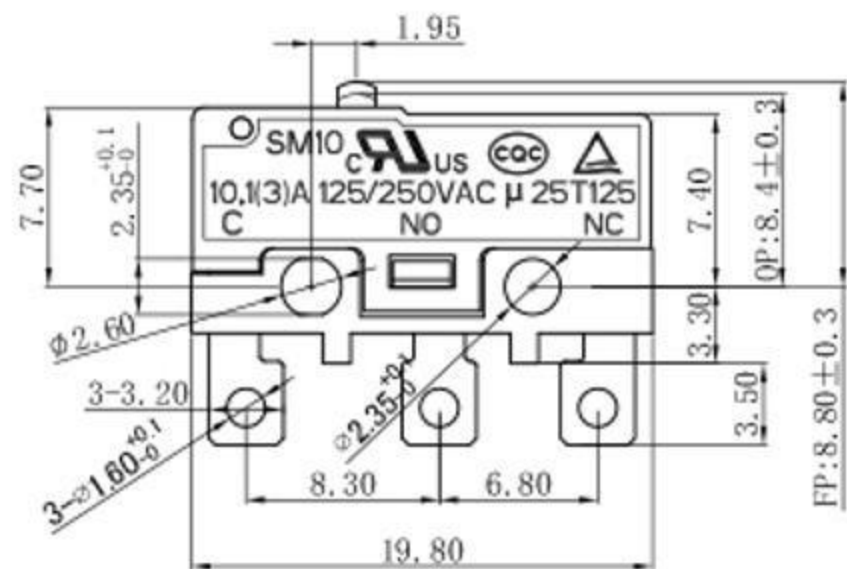

电路图

9	银触点	2	铜合金	
8	弹片触点	1	铜合金	
7	弹片	1	C5210	
6	NC端子	1	C2680	镀镍
5	NO端子	1	C2680	镀镍
4	COM端子	1	C2680	镀镍
3	按钮	1	PBT	UL94V-0
2	上盖	1	PBT	UL94V-0
1	底座	1	PBT	UL94V-0
序号	零件名称	数量	材质	备注

东莞市溪榜电子有限公司

制图	陈志鹏					
设计	廖晓斌					
审核	赖瑞坤	比例	SCALE	4:1	名称	微动开关
核准	廖晓斌	数量	QTY	1/1	料号	
一般公差	±0.20	单位	UNIT	mm	模具编号	
TOLEANCE	±0.10	角度	ANGLES	±2.0°	料号	
	±0.05				料号	

版本	ECN 编号	日期	更改内容	修改	核准
REV.	ECN NO.	DATE	DEFINITION	DATE	APPROVE



工程图

ENC 06X