

开关技术特性(Switch technical Characteristics):

项目 (ITEM)	技术参数 (technical parameter)	特性值 (Value)
1	电气额定值 (Electrical Rating)	5(2)A/10A/16(3)A/21(8)A 250VAC
2	接触电阻 (Contact Resistance)	≤30mΩ (初始值 Initial value)
3	绝缘电阻 (Insulation Resistance)	≥100MΩ (500VDC)
4	耐压强度 (Dielectric Voltage)	同极不相接端子间 (between non-connected terminals)
		端子与外壳或非载流金属零件之间 (between terminals and the metal frame)
5	电气寿命 (Electrical Life)	≥50000 cycles
6	机械寿命 (Mechanical Life)	≥1000000 cycles
7	工作温度 (Operating Temperature)	-25~125℃
8	操作频率 (Operating Frequency)	电气 (electrical) :15 cycles 机械 (Mechanical) :60 cycles
9	抗振动 (Vibration Proof)	振动频率 (Vibration Frequency): 10~55HZ; 振幅 (Amplitude): 1.5mm; 三向 (Three directions) :1H
10	可焊性 (Solder Ability): 超过 80%的浸锡面积被焊料所覆盖 (More than 80% of immersed part shall be covered with solder)	焊接温度 (Soldering Temperature): 235 ± 5℃ 浸渍时间 (Immersing Time): 2~3S
11	耐焊接热 (Solder Heat Resistance)	自动焊接 (Dip Soldering): 260 ± 5℃ 5 ± 1S 手工焊接 (Manual Soldering): 300 ± 5℃ 2~3S
12	安全认证 (Safety Approvals)	UL、CSA、VDE、ENEC、TUV、CE、KC、CQC
13	测试条件 (Test Conditions)	环境温度 (Ambient Temperature): 20 ± 5℃ 相对湿度 (Relative Humidity): 65 ± 5%RH 大气压 (Air Pressure): 86~106KPa

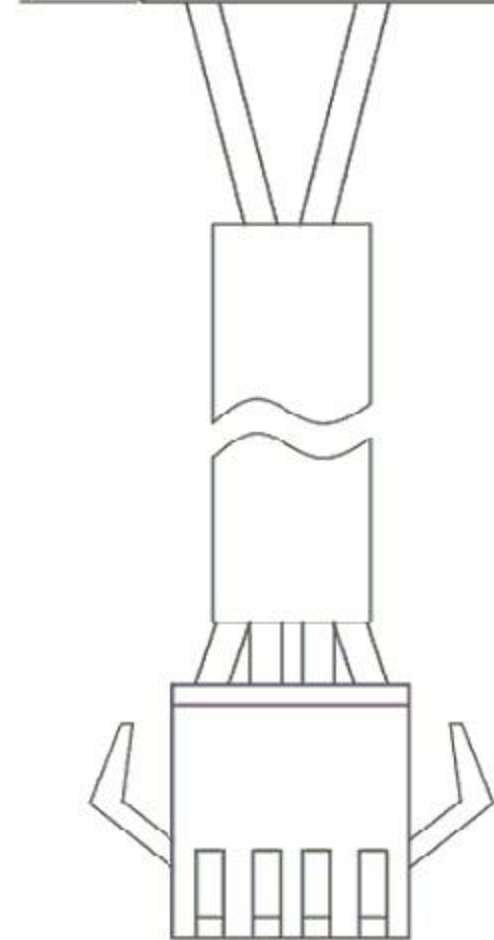

电路简图

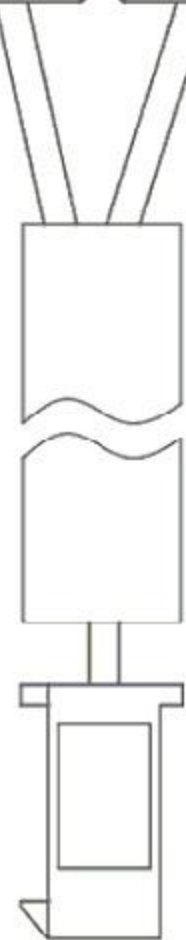
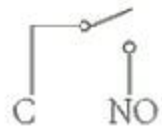

NO.	PARTS	MATERIALS	Q'TY							
8										
7										
6										
5	SPRING	SUS	1	NATURAL						
4	CAM STICK	SUS	1	NATURAL						
3	CASE	PA66/BRASS STRIP	1	GREY/Ag PLATED						
2	COVER	PA66	1	BLACK						
1	KNOB	PA66/PBS C5210R-EH	1	WHITE/Ag CLAD						
					TOLERANCE UNLESS SPECIFIED					
					WITHIN 1.5mm : ±0.1mm	A	2012-8-13	初版		
					OVER 1.5mm : ±0.2mm	ISSUE	DATE	DESCRIPTIONS OF REVISION		APPD.
					TITLE : Micro Switch		UNIT : mm	DRWG NO.:		
					MODEL:		SCALE: 5:1	DWN.		2012-8-13
					东莞市溪榜电子有限公司		CHK'D			2012-8-13
							APPD.			