

REV	MARK	DESCRIPTION	DRAFTED BY	DATE

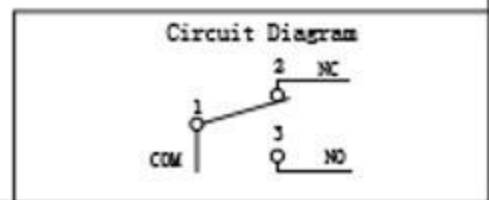
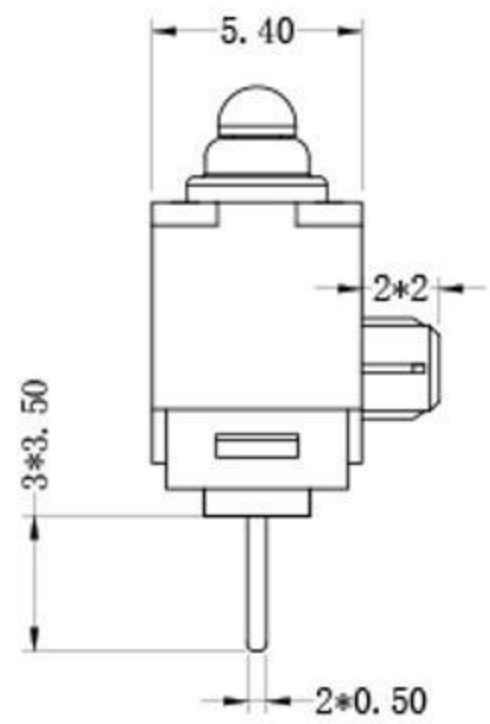
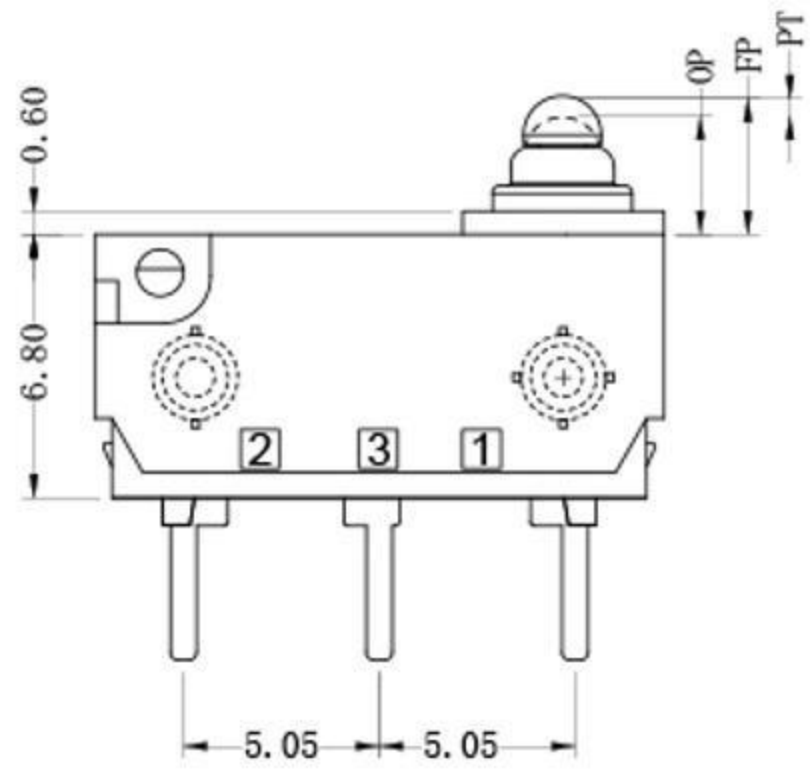
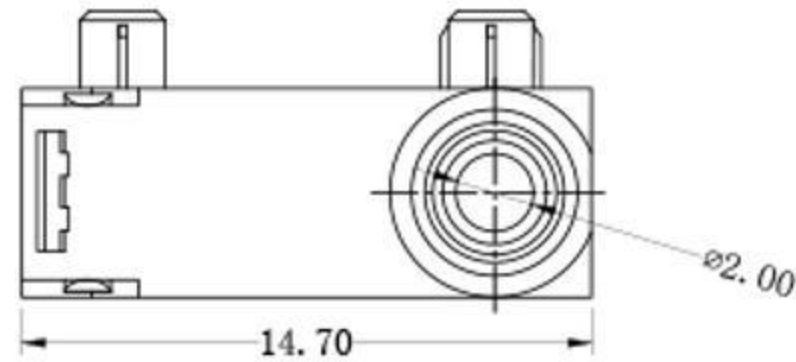

CHARACTERISTICS	
OPERATING FORCE (OF):	130gf Max.
RELEASE FORCE (RF):	30gf Min.
OPERATING POSITION:	6.6 ± 0.20 mm.
PRE TRAVEL:	0.8mm Max.
DIFFERENTIAL TRAVEL:	0.20mm Max.
OVER TRAVEL:	0.8mm Min.
FREE POSITION:	7.20mm Max.

ELECTRICAL DATA	
RATING	OPERATING LIFE
3A 12VDC	100,000 CYCLES
0.1A 48VDC 125/250VAC	100,000 CYCLES
MECHANICAL LIFE	500,000 CYCLES
GAP TYPE	MICRO
OPERATING TEMP.	$-40^{\circ}\text{C} \sim +85^{\circ}\text{C}$
WATERPROOF	IP67

OUTLINE DRAWING	
TITLE	H3 SERIES MICRO SWITCH
MODEL	H3-E1
PART NO.	
DRAFTED BY	LV ZHIPENG
CHECKED BY	YANG HONGTAO
APPROVED BY	TANG XIAOBO
DATE	2020-7-21

TOLERANCE UNLESS OTHERWISE SPECIFIED							
≤ 3	1~3	3~10	10~30	30~100	100~200	ANGLE	
± 0.2	± 0.3	± 0.4	± 0.6	± 1.0	± 1.5	$\pm 3.0^{\circ}$	
SCALE						UNIT	
						mm	
VERSION						REV	
						A1	

东莞市溪榜电子有限公司