

REV	MARK	DESCRIPTION	DRAFTED. BY	DATE

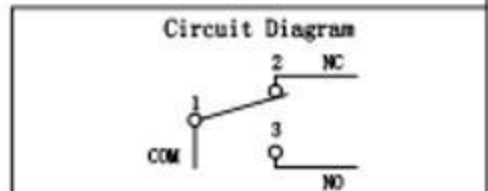
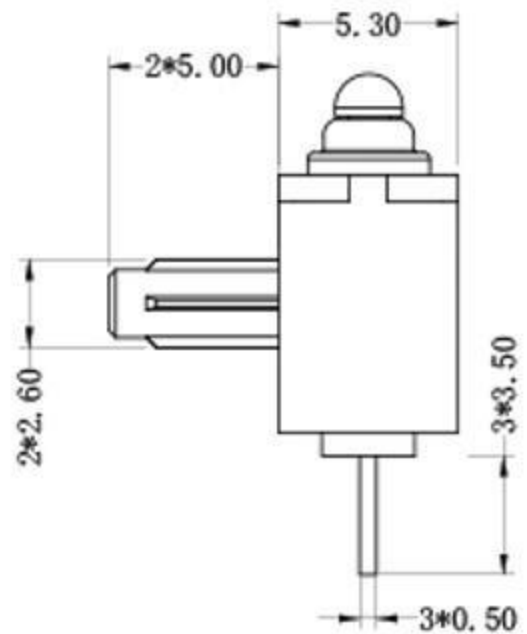
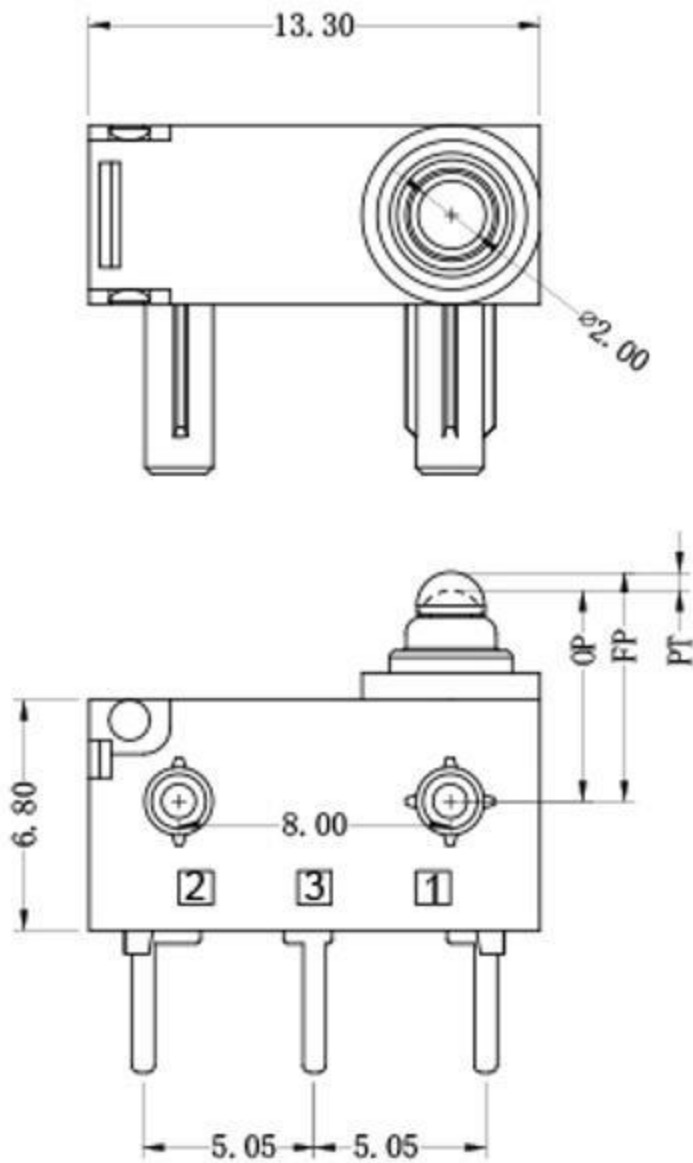

ELECTRICAL DATA	
RATING	OPERATING LIFE
3A 12VDC	100,000 CYCLES
0.1A 48VDC 125/250VAC	100,000 CYCLES
MECHANICAL LIFE	500,000 CYCLES
GAP TYPE	MICRO
OPERATING TEMP	-40°C ~ +85°C
WATERPROOF	IP67

OUTLINE DRAWING		TOLERANCE UNLESS OTHERWISE SPECIFIED								
TITLE	H3 SERIES MICRO SWITCH	<3	1~3	3~10	10~30	30~100	100~200	ANGLE		
MODEL	H3-D4	±0.2	±0.3	±0.4	±0.6	±1.0	±1.5	±3.0°		
PART NO.										
DRAFTED BY	LV ZHIPENG								DATE	2020-9-7
CHECKED BY	YANG HONGTAO									
APPROVED BY	TANG XIAOBO									

SCALE	
UNIT	MM
VERSION	REV A1

东莞市溪榜电子有限公司

CHARACTERISTICS	
OPERATING FORCE (OF):	130gf Max.
RELEASE FORCE (RF):	30gf Min.
OPERATING POSITION:	6.40 ± 0.3 mm.
PRE TRAVEL:	1.30mm Max.
DIFFERENTIAL TRAVEL:	0.25mm Max.
FREE POSITION:	7.20mm Max.

H  
G  
F  
E  
D  
C  
B  
A

1 2 3 4 5 6 7 8 9 10