

REV	MARK	DESCRIPTION	DRAFTED. BY	DATE

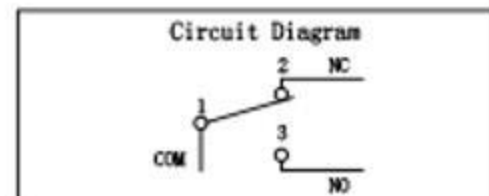
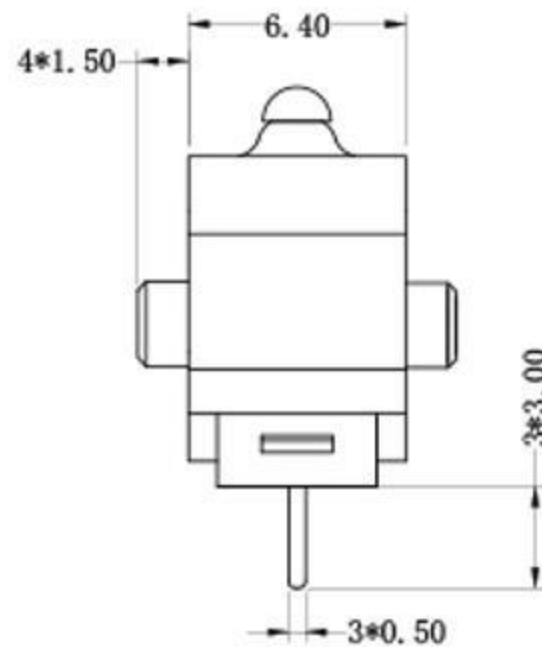
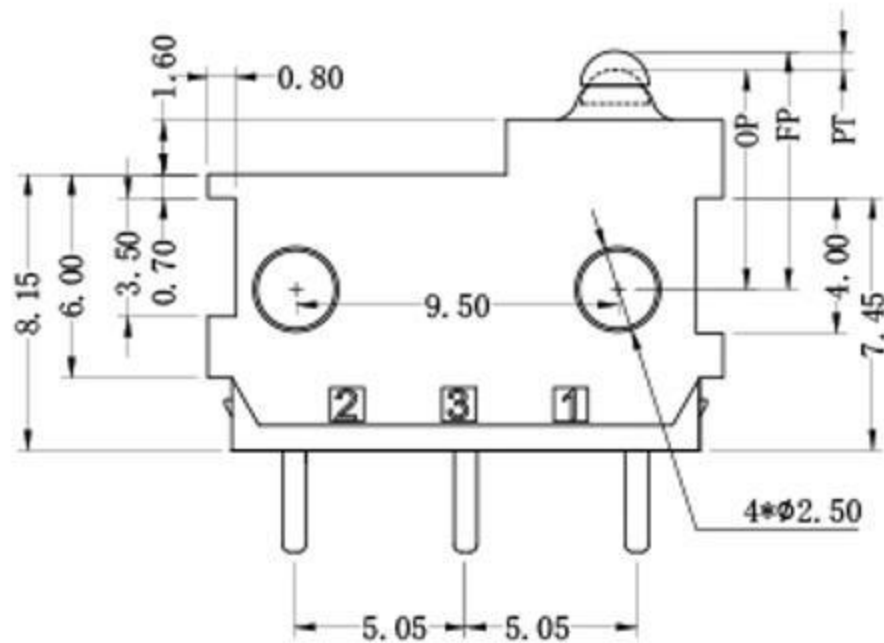
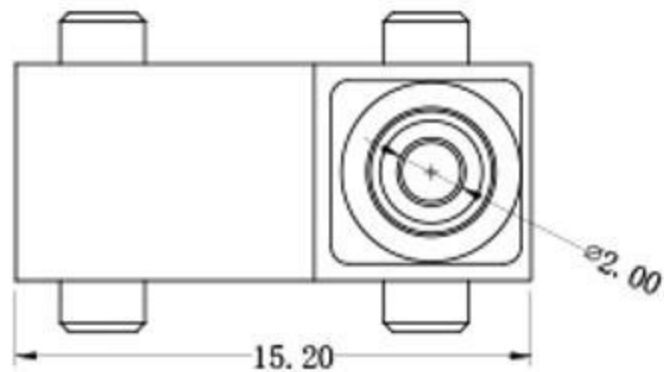

CHARACTERISTICS	
OPERATING FORCE (OF):	130gf Max.
RELEASE FORCE (RF):	15gf Min.
OPERATING POSITION:	6.85 ± 0.2 mm.
PRE TRAVEL:	0.80mm Max.
DIFFERENTIAL TRAVEL:	0.20mm Max.
FREE POSITION:	7.50mm Max.

RATING	OPERATING LIFE
3A 12VDC	100,000 CYCLES
0.1A 48VDC 125/250VAC	100,000 CYCLES

MECHANICAL LIFE	500,000 CYCLES
GAP TYPE	MICRO
OPERATING TEMP	-40°C ~ +85°C
WATERPROOF	IP67

OUTLINE DRAWING		TOLERANCE UNLESS OTHERWISE SPECIFIED												
TITLE	H3 SERIES MICRO SWITCH	<3	1~3	3~10	10~30	30~100	100~200	ANGLE						
MODEL	H3-C2	±0.2	±0.3	±0.4	±0.6	±1.0	±1.5	±3.0°						
PART NO.														
DRAFTED BY	LV ZHIPENG								DATE	2020-9-7				
CHECKED BY	YANG HONGTAO													
APPROVED BY	TANG XIAOBO	<table border="1"> <thead> <tr> <th>SCALE</th> <th>UNIT</th> <th>REV</th> </tr> </thead> <tbody> <tr> <td></td> <td></td> <td>A1</td> </tr> </tbody> </table>							SCALE	UNIT	REV			A1
SCALE	UNIT	REV												
		A1												

东莞市溪榜电子有限公司