

REV	MARK	DESCRIPTION	DRAFTED BY	DATE

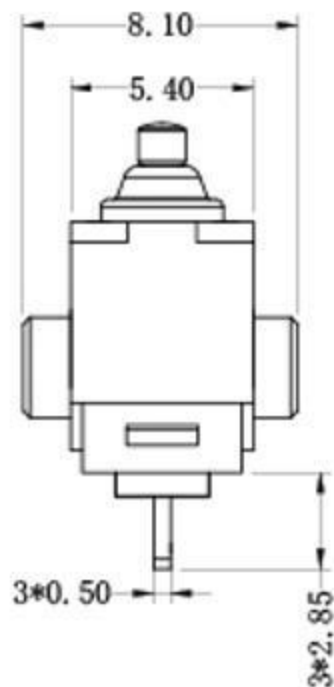

Circuit Diagram

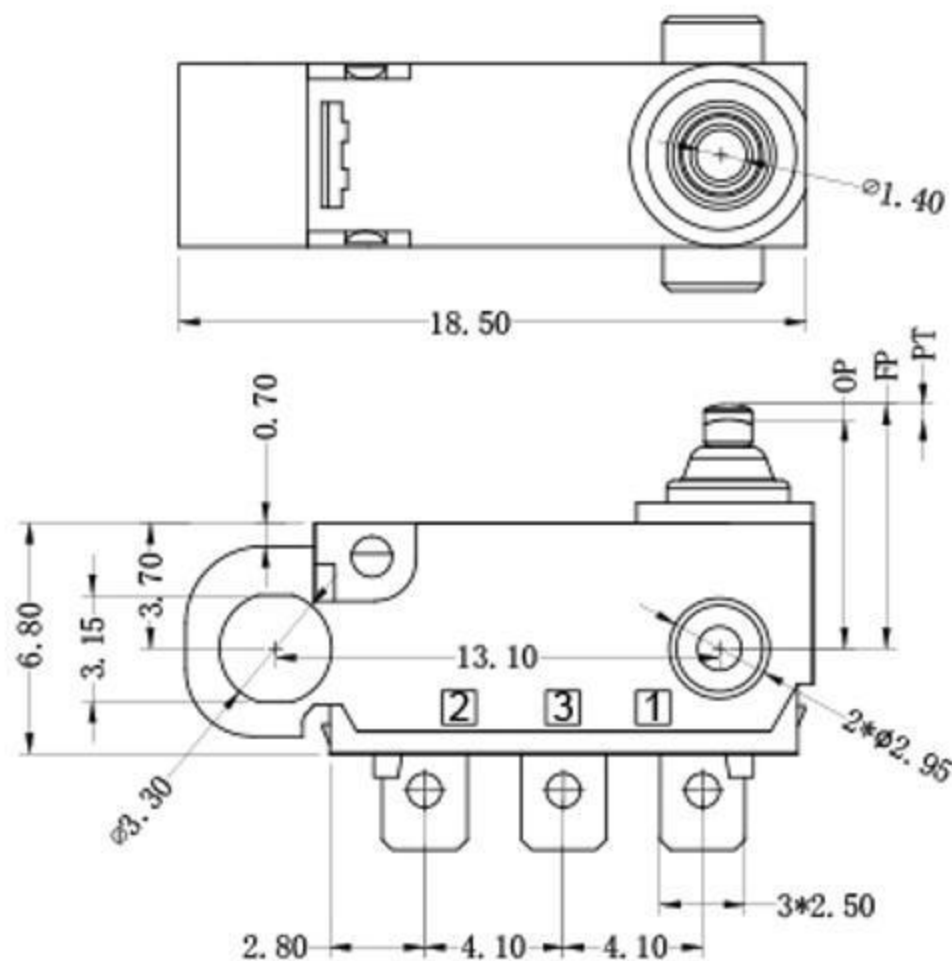
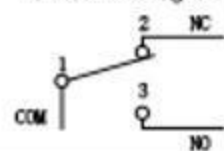

CHARACTERISTICS

OPERATING FORCE (OF):	130gf Max.
RELEASE FORCE (RF):	13gf Min.
OPERATING POSITION:	6.75±0.2 mm.
PRE TRAVEL:	0.80mm Max.
DIFFERENTIAL TRAVEL:	0.20mm Max.
FREE POSITION:	7.35mm Max.

ELECTRICAL DATA

RATING	OPERATING LIFE
3A 12VDC	100,000 CYCLES
0.1A 48VDC 125/250VAC	100,000 CYCLES

MECHANICAL LIFE	500,000 CYCLES
GAP TYPE	MICRO
OPERATING TEMP	-40℃~+85℃
WATERPROOF	IP67

OUTLINE DRAWING

TITLE	H3 SERIES MICRO SWITCH	TOLERANCE UNLESS OTHERWISE SPECIFIED						
MODEL	H3-B2	≤3	1~3	3~10	10~30	30~100	100~200	ANGLE
		±0.2	±0.3	±0.4	±0.6	±1.0	±1.5	±3.0°

PART NO.	
DRAFTED BY	LV ZHIPENG
CHECKED BY	YANG HONGTAO
APPROVED BY	TANG XIAOBO
DATE	2020-8-10

SCALE	
UNIT	MM
VERSION	REV A1

东莞市溪榜电子有限公司