

REV	MARK	DESCRIPTION	DRAFTED. BY	DATE

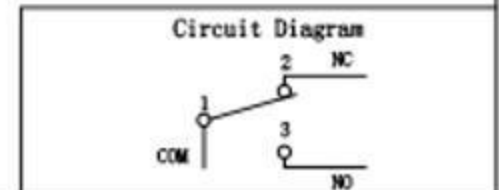
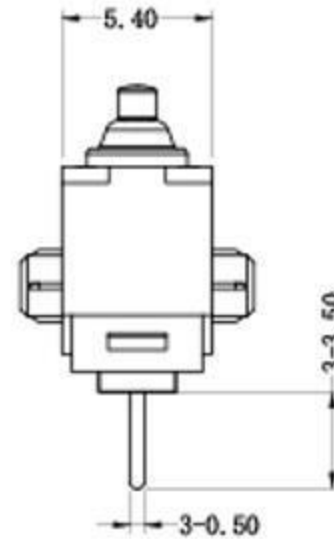
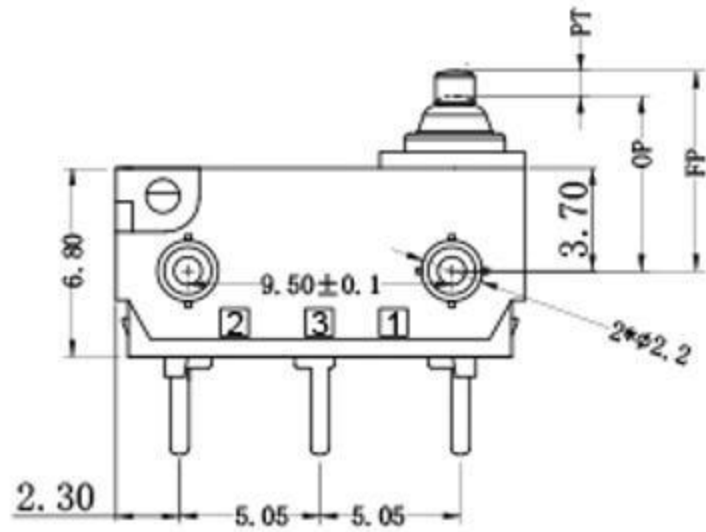
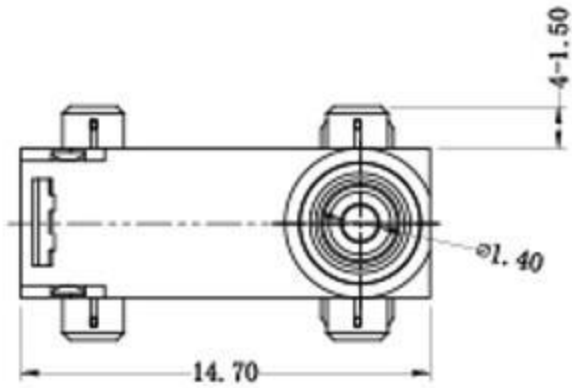

CHARACTERISTICS	
OPERATING FORCE (OF):	130gf Max.
RELEASE FORCE (RF):	13gf Min.
OPERATING POSITION:	6.75±0.2 mm.
PRE TRAVEL:	0.8mm Max.
DIFFERENTIAL TRAVEL:	0.2mm Max.
FREE POSITION:	7.35mm Max.

ELECTRICAL DATA	
RATING	OPERATING LIFE
3A 12VDC	100,000 CYCLES
0.1A 48VDC 125/250VAC	100,000 CYCLES
MECHANICAL LIFE	500,000 CYCLES
GAP TYPE	MICRO
OPERATING TEMP	-40°C~+85°C
WATERPROOF	IP67

OUTLINE DRAWING		TOLERANCE UNLESS OTHERWISE SPECIFIED									
TITLE	H3 SERIES MICRO SWITCH	<3	1~3	3~10	10~30	30~100	100~200	ANGLE			
MODEL	H3-A8	±0.2	±0.3	±0.4	±0.6	±1.0	±1.5	±3.0°			
PART NO.								SCALE			
DRAFTED BY	LV ZHIPENG							DATE	2020-6-15	UNIT	MM
CHECKED BY	YANG HONGTAO							东莞市溪榜电子有限公司 东 莞 市 溪 榜 电 子 有 限 公 司		VERSION	REV
APPROVED BY	TANG XIAOBO										

1 2 3 4 5 6 7 8 9 10