

REV	MARK	DESCRIPTION	DRAFTED. BY	DATE

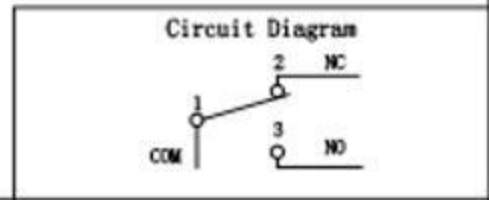
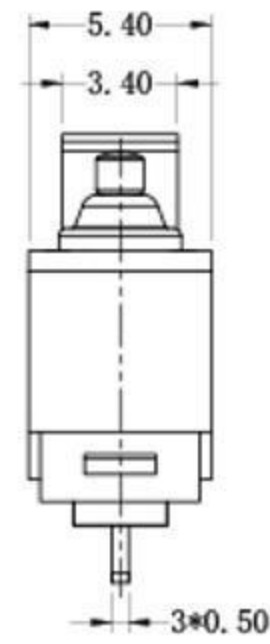
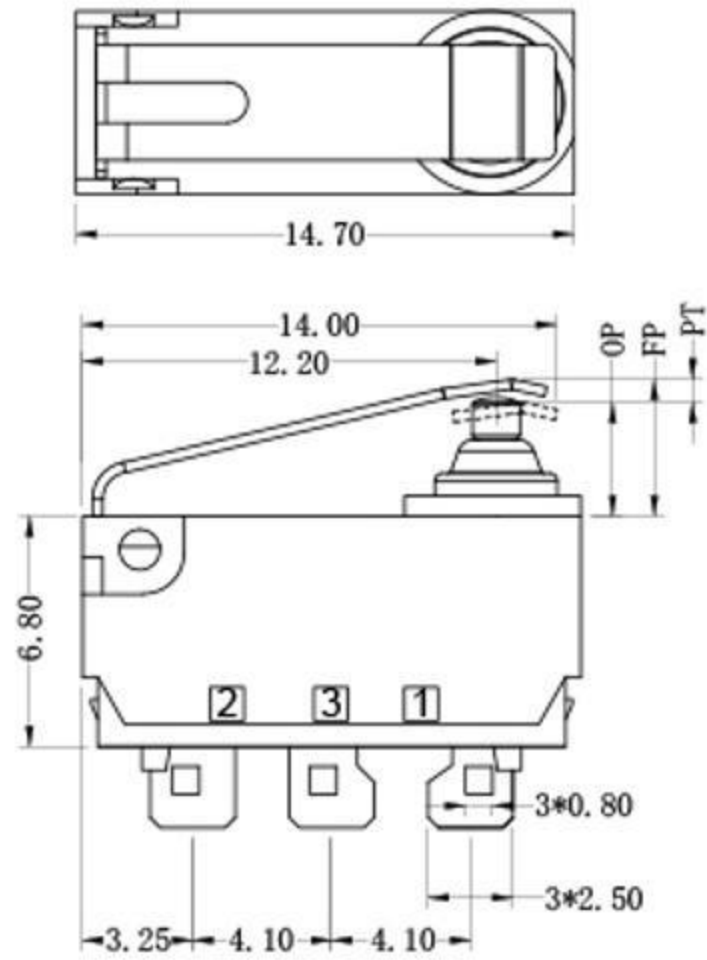

CHARACTERISTICS	
OPERATING FORCE (OF):	220gf Max.
RELEASE FORCE (RF):	30gf Min.
OPERATING POSITION:	3.4±0.5 mm.
PRE TRAVEL:	3mm Max.
DIFFERENTIAL TRAVEL:	0.5mm Max.
FREE POSITION:	5.7mm Max.

ELECTRICAL DATA	
RATING	OPERATING LIFE
3A 12VDC	100,000 CYCLES
0.1A 48VDC 125/250VAC	100,000 CYCLES

MECHANICAL LIFE	500,000 CYCLES
GAP TYPE	MICRO
OPERATING TEMP	-40℃~+85℃
WATERPROOF	IP67

OUTLINE DRAWING		TOLERANCE UNLESS OTHERWISE SPECIFIED							
TITLE	H3 SERIES MICRO SWITCH	≤3	1~3	3~10	10~30	30~100	100~200	ANGLE	
MODEL	H3-A1	±0.2	±0.3	±0.4	±0.6	±1.0	±1.5	±3.0°	
PART NO.								SCALE	
DRAFTED BY	LV ZHIPENG	DATE	2020-6-15					UNIT	
CHECKED BY	YANG HONGTAO								VERSION
APPROVED BY	TANG XIAOBO								REV
									A1

东莞市溪榜电子有限公司