

东莞市溪榜电子有限

PB07

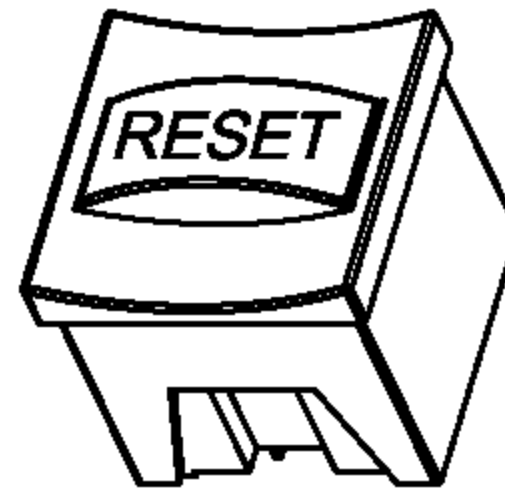
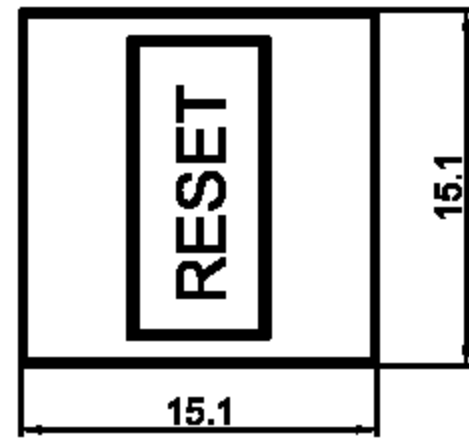

Rating: 100mA 30VDC ;
 Contact Resistance: 100mΩ Max. ;
 Insulation Resistance:DC 500V 100MΩ Min. ;
 Dielectric Strength:AC 250V 1 minute
 Total Travel: 2.5±0.5mm
 Operating Force:200±100gf
 Mechanical Life: Over 50,000 cycles
 Electrical Life: Over 10,000 cycles
 Operating Temperature:-20°C~70°C
 Manual welding:350°C for 3 Seconds

MATERIAL:

Outer Frame:ABS;
 Base:ABS ;
 Actuator:ABS
 Terminal: Brass,Silver or Tin plated .

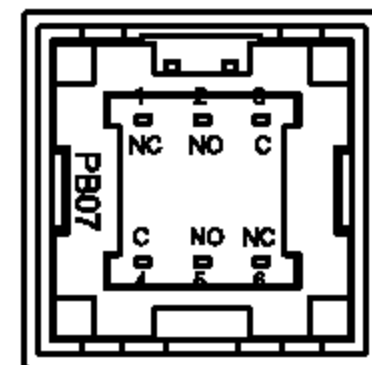
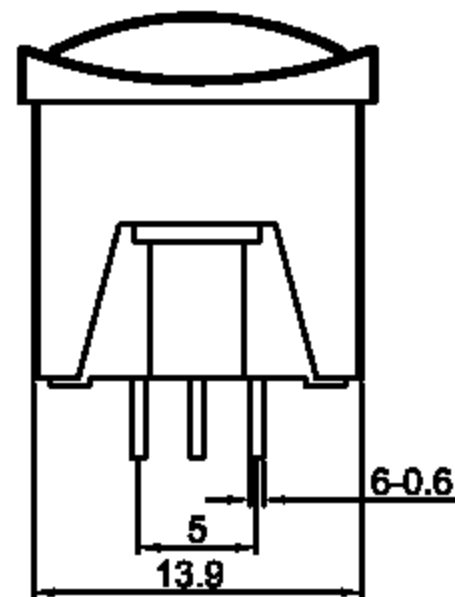
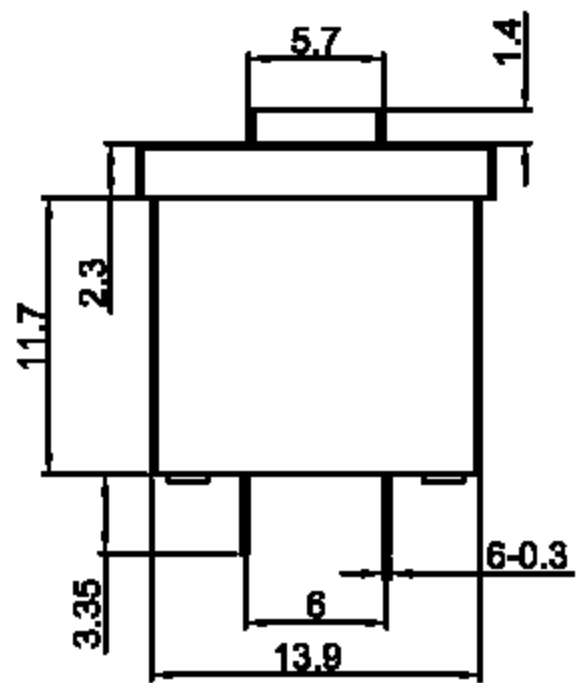

BOTTOM VIEW

Contact Configuration

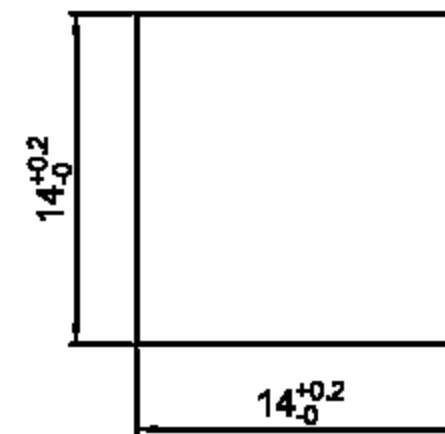
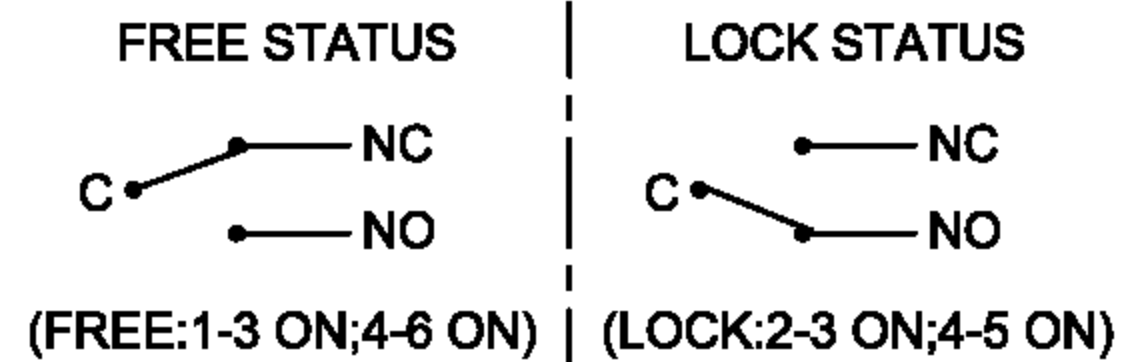

PANEL HOLE

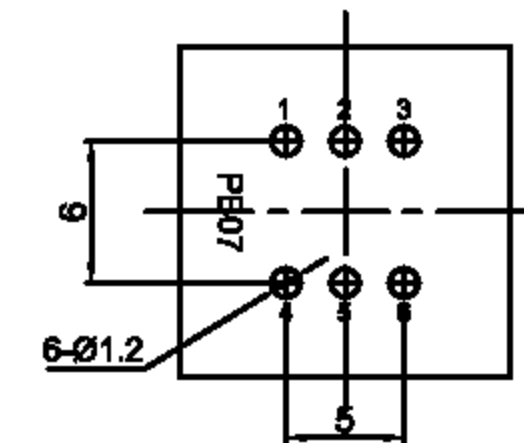

PCB HOLE(BOTTOM VIEW)

Y	Yellow	黄色
W	White	白色
U	Blue	蓝色
R	Red	红色
G	Green	绿色
B	Black	黑色
A	Gray	灰色
CAP COLOR (X)		

Note:

1.This product is strictly prohibited wave soldering and reflow soldering,please use the manual welding processing, temperature of 350°±5°and time is 3±0.5 seconds;
 2.After the product is welded on the PCB board,it is prohibited to use any solvent to clean the PCB board,and avoid the influence of the inner product.

				公差 TOLERANCES		.X± 0.3 .XX± 0.15		角度 ANGLE ± 1°		单位 DIMENSION UNIT mm.	
				视角 VIEWING ANGLE	比例尺 SCALE	NONE	日期 DATE	2016.10.07	品名 TITLE		图号 DRAWING NO
A1	增加产品焊锡说明	2016.10.07	N/A	核准	Richard	核对	Sinc	绘图	姜庆勇		
A0	New Issue	2011.12.08	N/A	核 准	Richard	核 对	Sinc	绘 图	姜庆勇		
版本 VBR.	变更说明 CHANGE DESCRIPTION	日期 DATE	ECN NO.	APPROVED BY	Richard	CHECKED BY	Sinc	DRAWN BY	姜庆勇		