

P. C. B LAYOUT

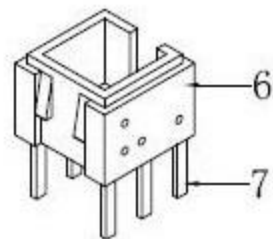
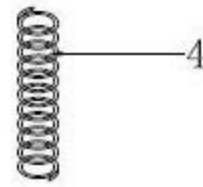
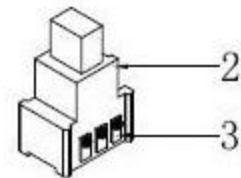
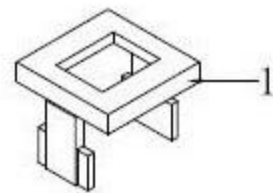
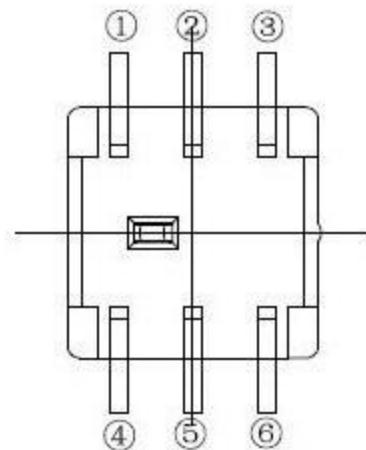

SPECIFICATIONS

- (1) LIFE TEST: 10000 cycles at a speed of 15-18 cycles
- (2) CONTACT RESISTANCE: 100mΩ max
- (3) INSULATION RESISTANCE: 100MΩ min
- (4) DIELECTRIC STRENGTH: 250V AC FOR 1MIN
- (5) OPERATING TEMPERATURE: -16°C - +60°C
- (6) RATING: 0.1A 30V DC
- (7) FUNCTION: 2P2T
- (8) TIMING: NON-SHORTING
- (9) OPERATING FORCE: 180gf ± 50gf

8					TOLERANCE UNLESS SPECIFIED				
7					WITHIN 1.5mm : ±0.1mm		A	2016-10-14	初版
6					OVER 1.5mm : ±0.2mm		ISSUE	DATE	DESCRIPTIONS OF REVISION
5	SPRING	SUS304	1	NATURAL	TITLE : VERTICAL PUSH SWITCH		UNIT : mm		DRWG NO.:
4	CAM STICK	SUS304	1	NATURAL	MODEL:		SCALE: 5:1		DWN.
3	CASE	PA66/BRASS STRIP	1	GREY/Ag PLATED	东莞市溪榜电子有限公司		2016-10-14		2016-10-14
2	COVER	PA66+15%F.G	1	BLACK					CHK'D
1	KNOB	PA66+15%F.G/PBS STRIP	1	BLACK/Ag CLAD					APPD.
NO.	PARTS	MATERIALS	Q'TY						