

**RoHS**

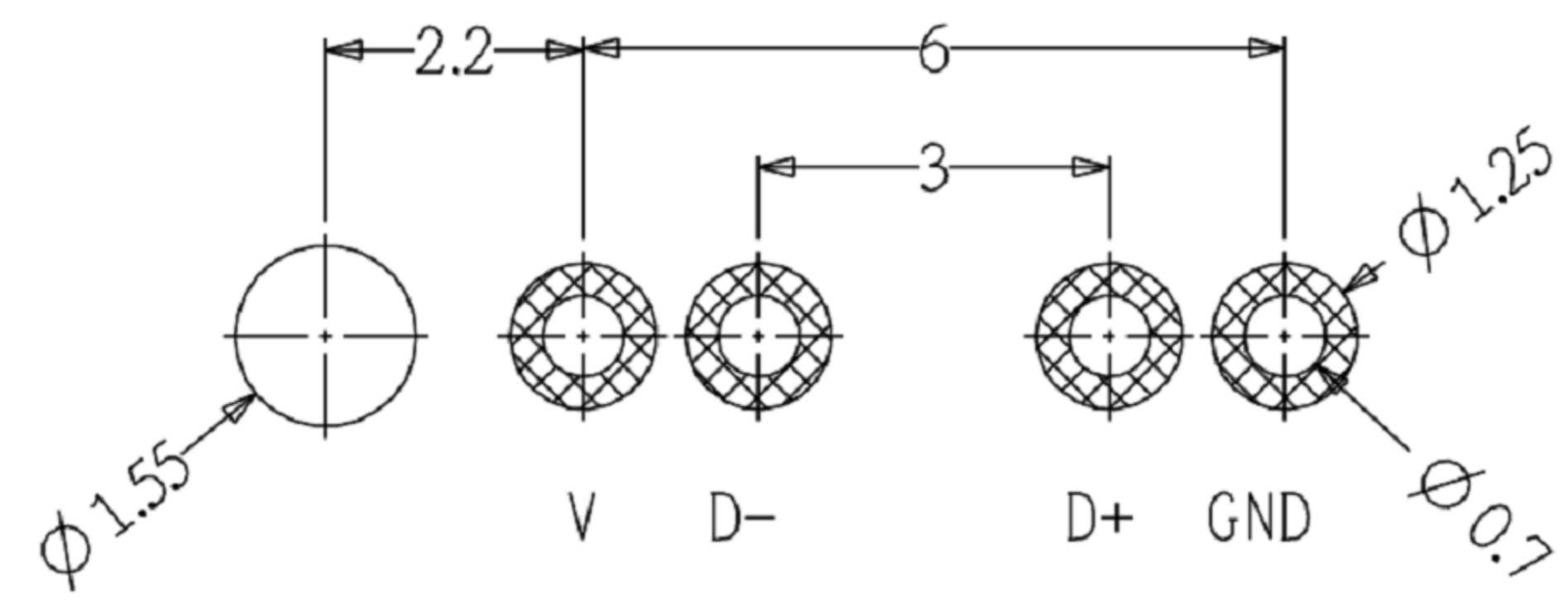
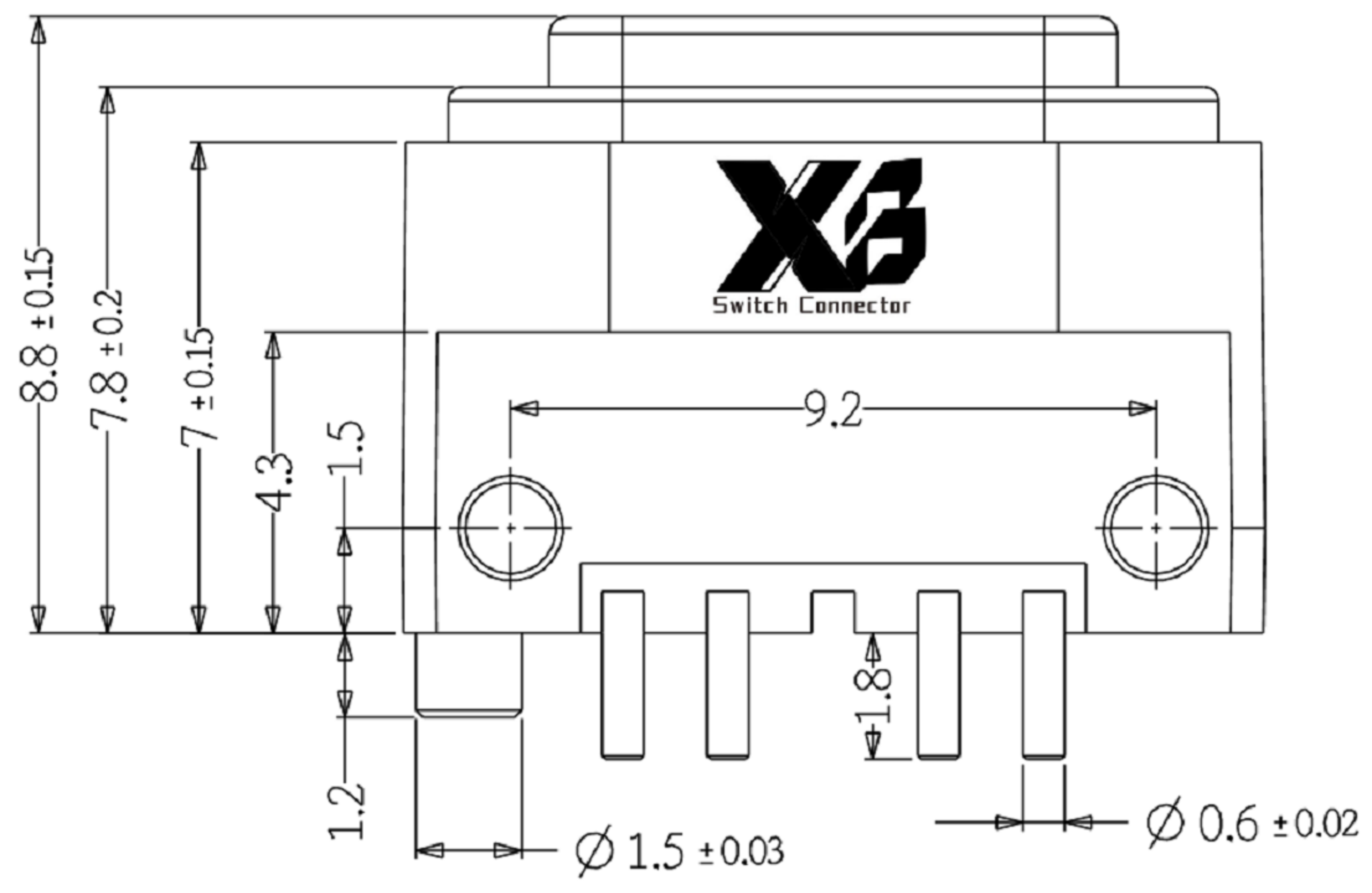
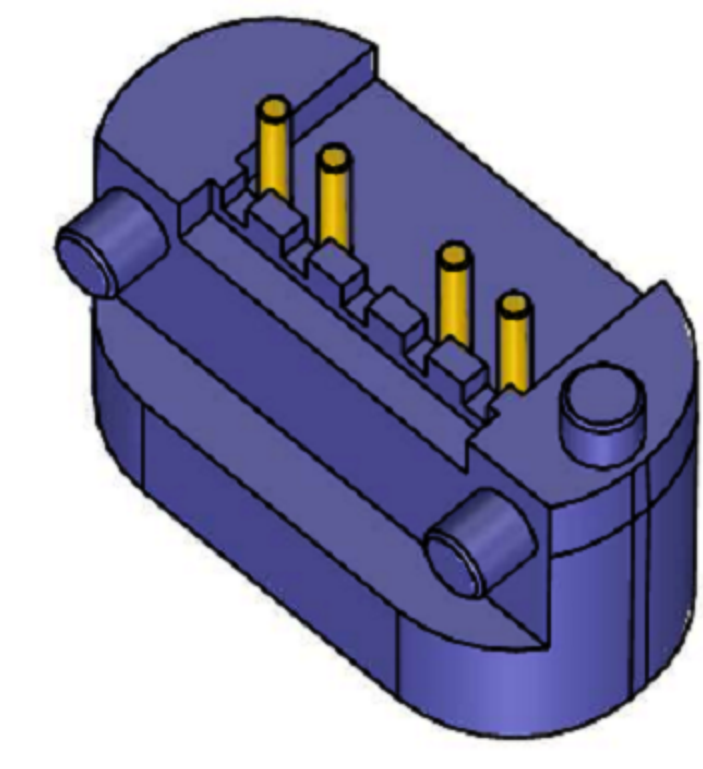
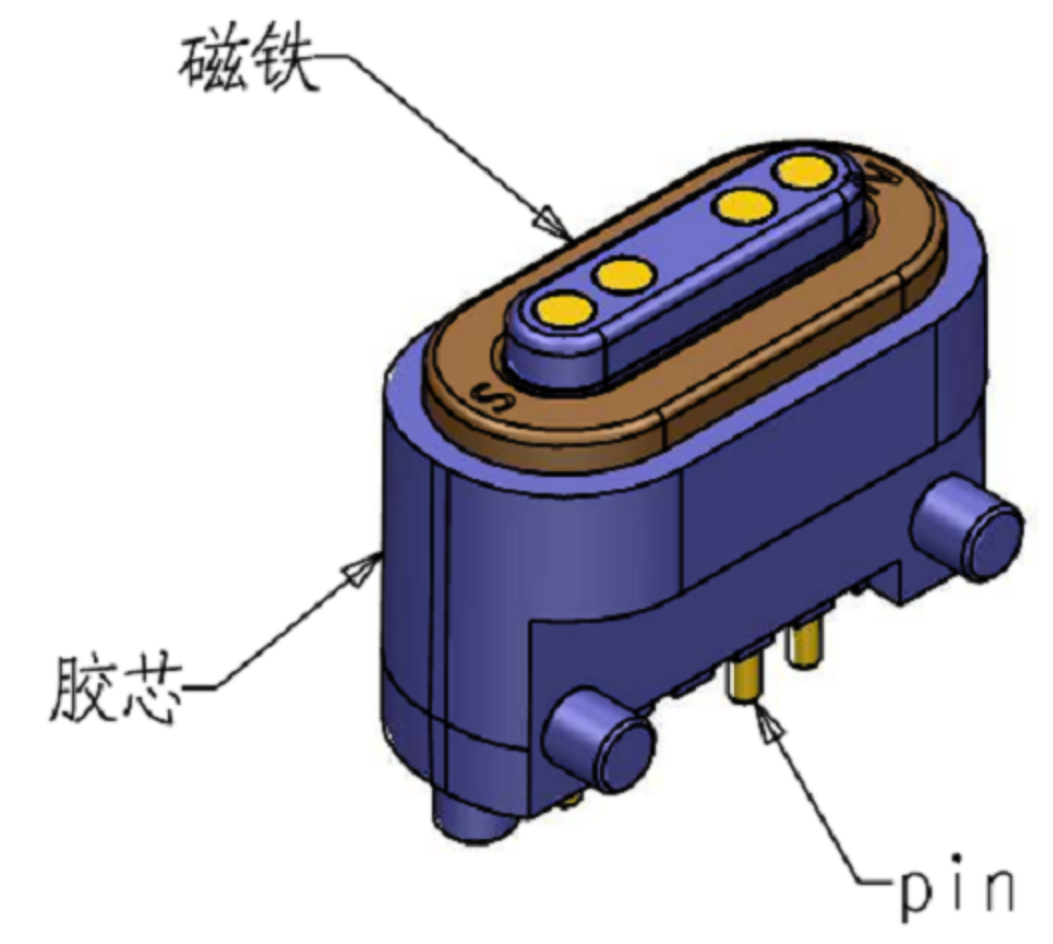
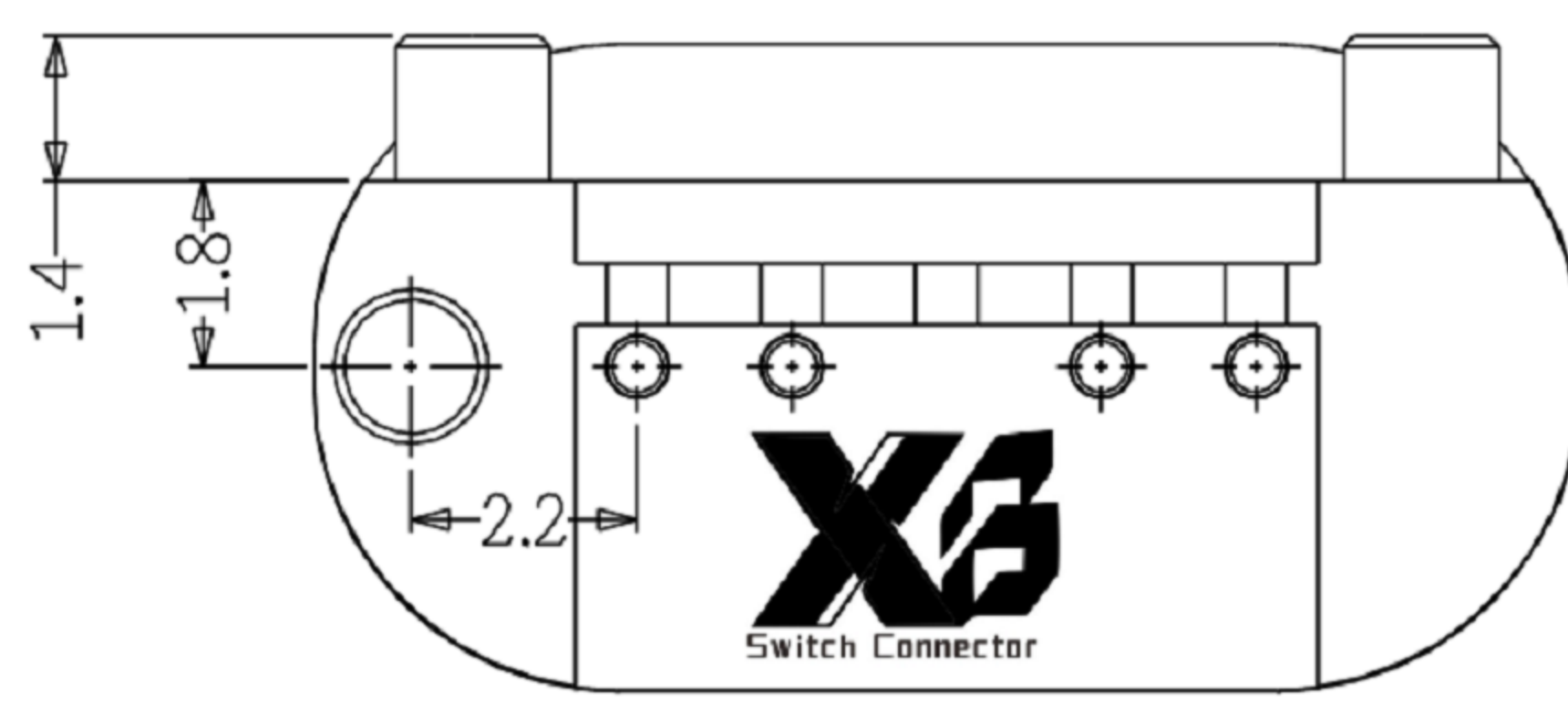
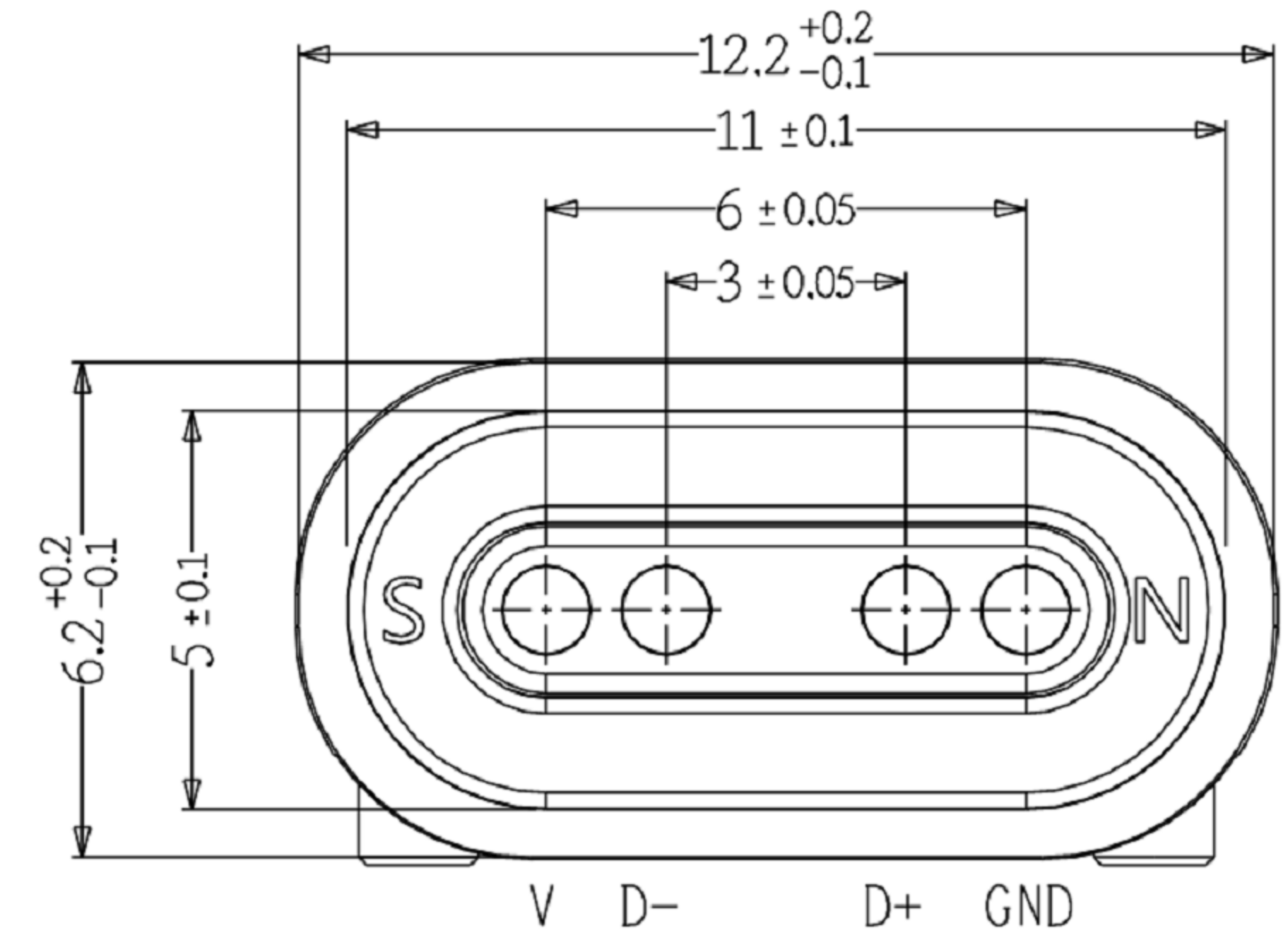

**NOTE**

1. Material  
Plunger: Brass  
Barrel: Brass  
Spring: SUS  
Housing: PA46
2. Plating  
Plunger: Au over NI  
Barrel: Au over NI
3. Electrical  
Rated current & voltage: DC 12V; 2.0A Max.
4. Mechanical  
Spring force: 60g±20% at normal working height  
Durability: 10,000 cycles (minimum)
5. To ensure the best usage, please operate it based on the working height. Based on the engineering drawings, shall not exceed the maximum allowed compression.
6. To avoid arcing issue, The adaptor start to power supply after connector mated fully.

**XGB** 东莞市溪榜电子有限公司  
DONG GUAN XI BANG ELECTRONICS CO., LTD.

TOLERANCE UNLESS OTHERWISE STATED:  
Up to 5 ±0.2  
Above 5 ~ 15 ±0.3  
Above 15 ~ 30 ±0.4  
Above 30 ~ 50 ±0.5  
Angle ±0.3°

3RD. ANGEL'S

UNITS MM

DRAWN BY:	DATE
Long. Liu. Ting	23. 4. 8
CHECKED BY:	DATE
Lai. Hai. Jie	23. 4. 8
APPROVED BY:	DATE
He. Long. Fei	23. 4. 8

MAT'L	TITLE	CONNECTOR
FINISH	MODLE	POGO PIN
SCALE	DWG NO.	XB-PGC-CT-300M-4P-M
SHEET NO.	PART NO.	Magnetic PoGo Pin
		SIZE A4
		VER R

ITEM NO.	DESCRIPTION	DRAWN	DATE