

推荐封装尺寸(公差±0.05mm)
Recommended layout
General tolerance: ±0.05mm

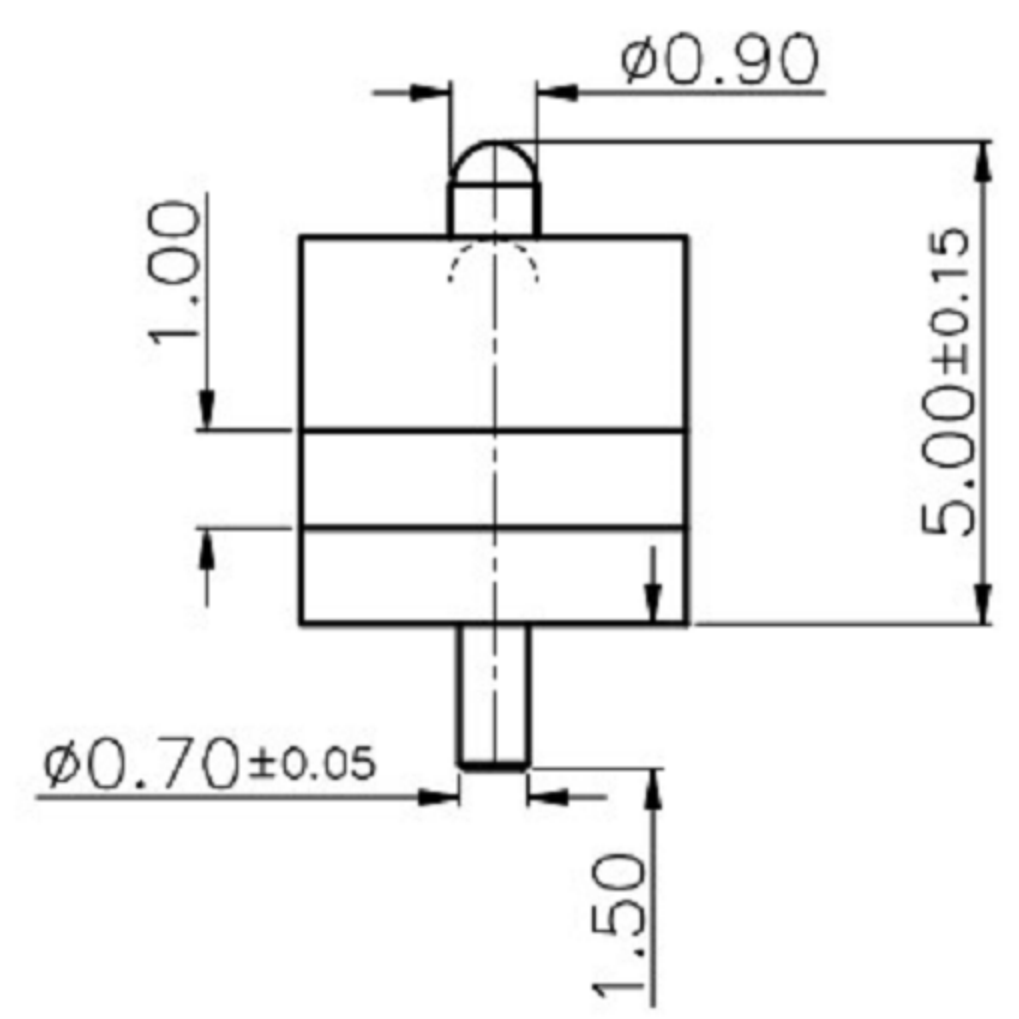
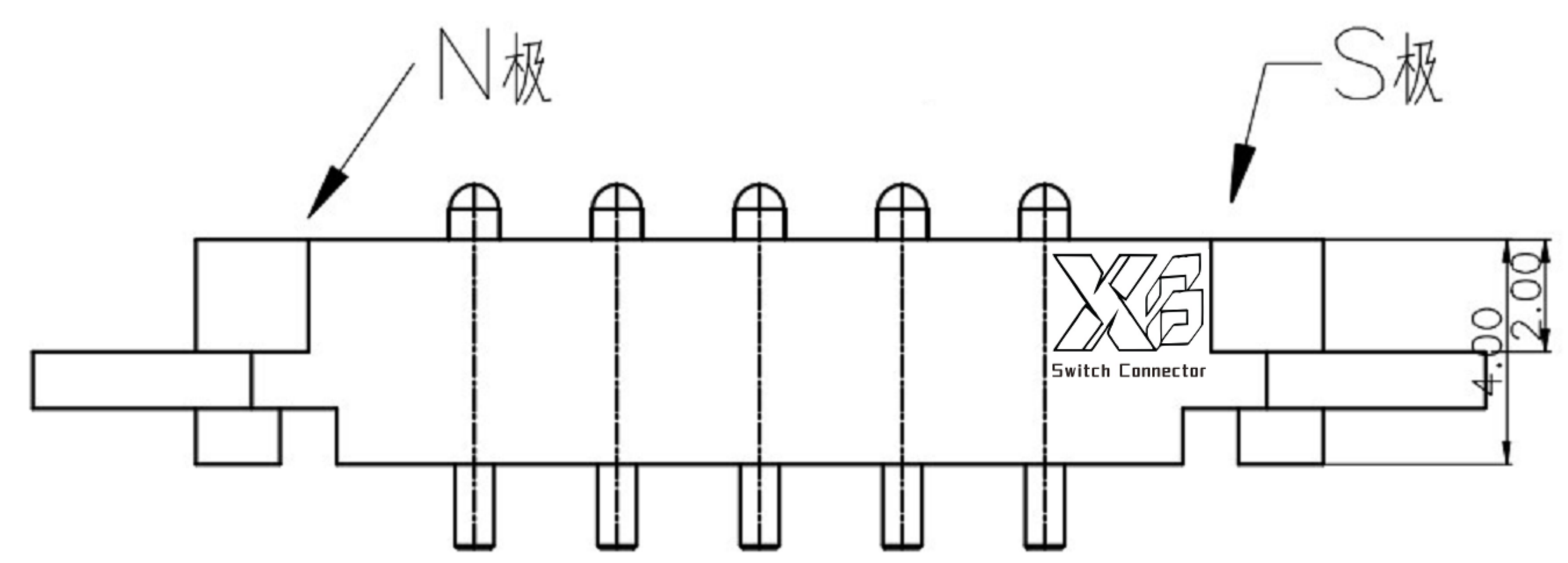

NOTE

1. Material
 Plunger: Brass
 Barrel: Brass
 Spring: SUS
 Housing: PA46
2. Plating
 Plunger: Au over NI
 Barrel: Au over NI
3. Electrical
 Rated current & voltage: DC 12V; 2.0A Max.
4. Mechanical
 Spring force: 60g±20% at normal working height
 Durability: 10,000 cycles(minimum)
5. To ensure the best usage, please operate it based on the working height. Based on the engineering drawings, shall not exceed the maximum allowed compression.
6. To avoid arcing issue, The adaptor start to power supply after connector mated fully.

XIB 东莞市溪榜电子有限公司
DONG GUAN XI BANG ELECTRONICS CO., LTD.

TOLERANCE UNLESS OTHERWISE STATED:
 Up to 5 ±0.2
 Above 5 ~ 15 ±0.3
 Above 15 ~ 30 ±0.4
 Above 30 ~ 50 ±0.5
 Angle ±0.3°

3RD. ANGEL'S

UNITS MM

DRAWN BY:	DATE	MAT'L	TITLE	CONNECTOR
Jack Lu	04/01/21			
CHECKED BY:	DATE	FINISH	MODLE	POGO PIN
Jacky Chen	04/01/21			
APPROVED BY:	DATE	SCALE	DWG NO.	XB-PGC-CT-501G-E
Tony Kao	04/01/21	1:1	PART NO.	Magnetic PoGo Pin
SHEET NO.	1 of 1			

ITEM NO.	DESCRIPTION	DRAWN	DATE