

RoHS

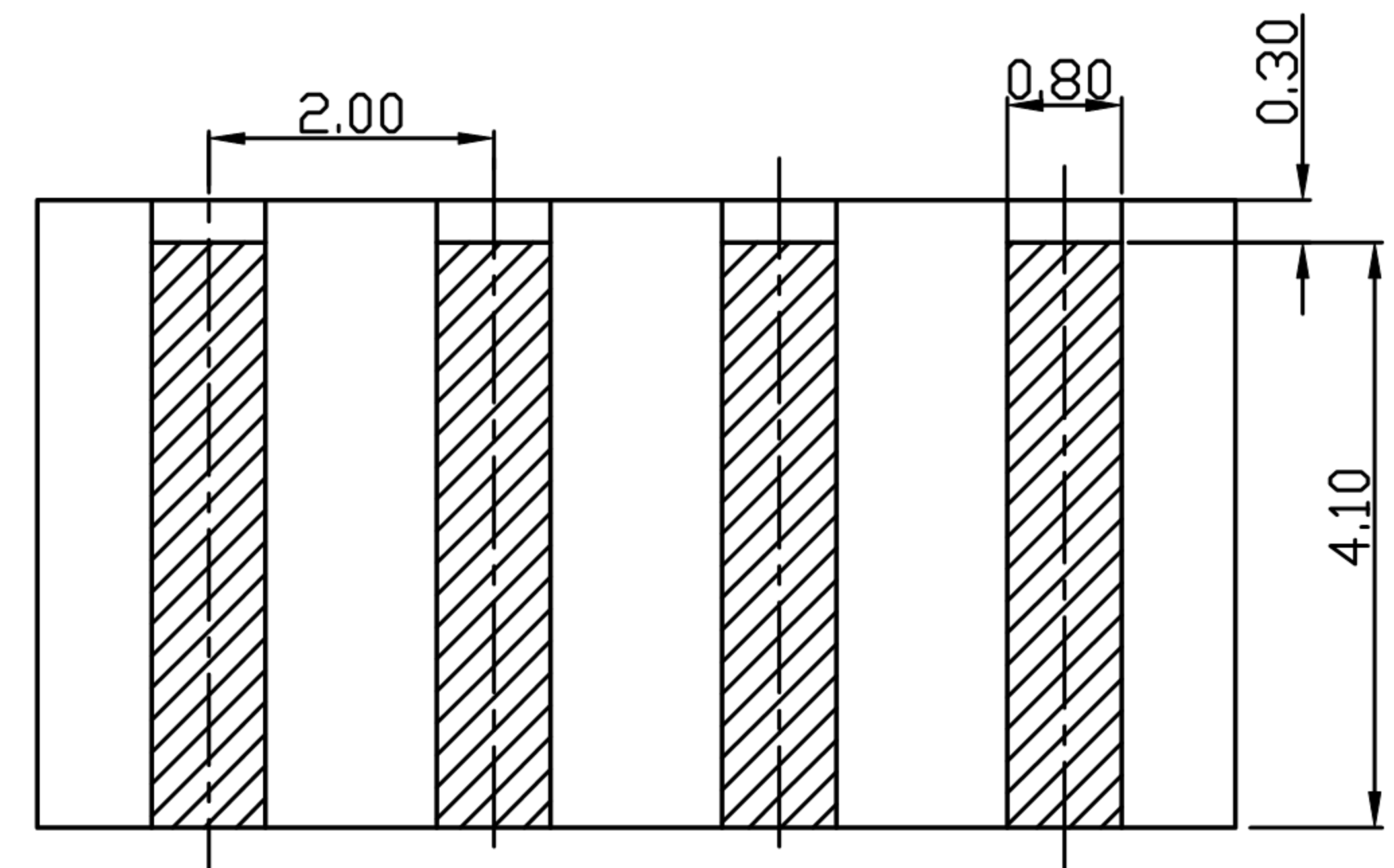
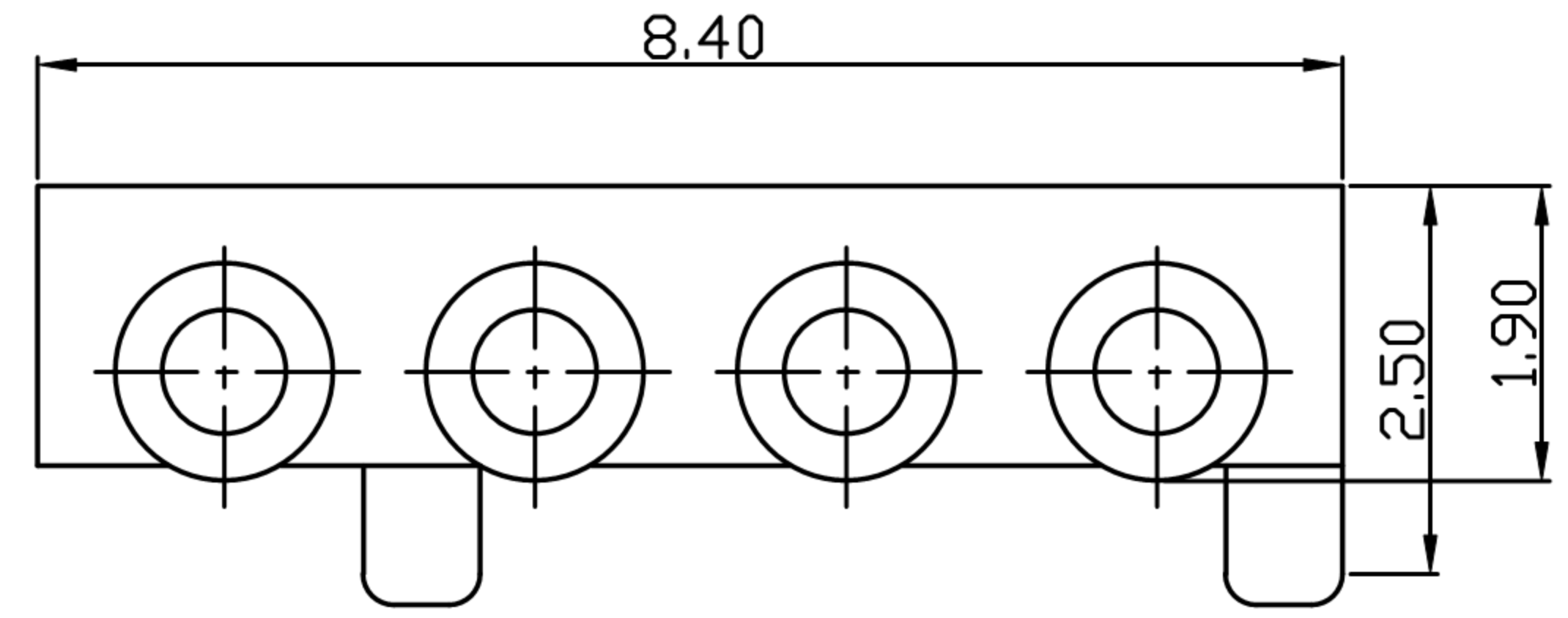
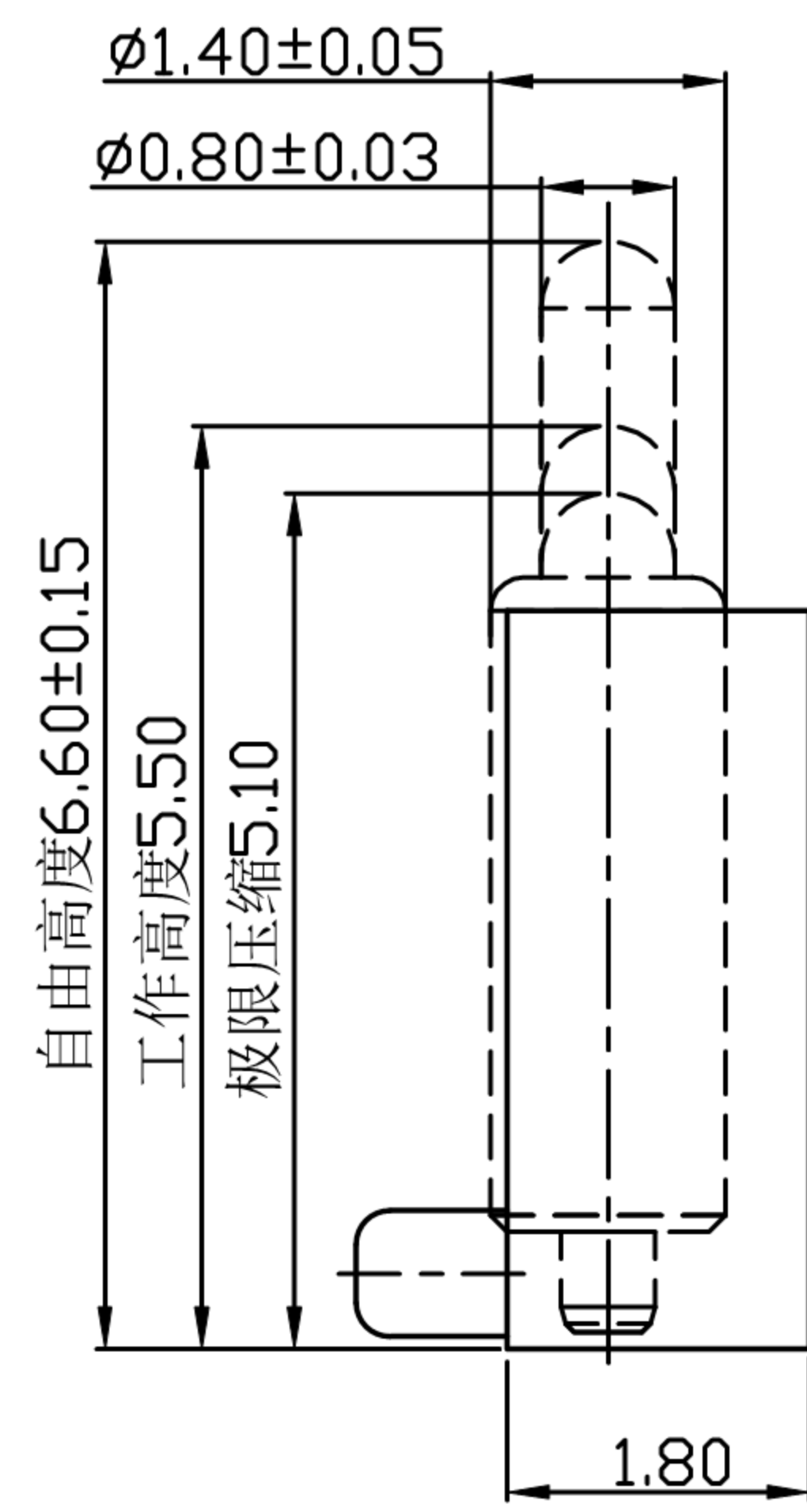
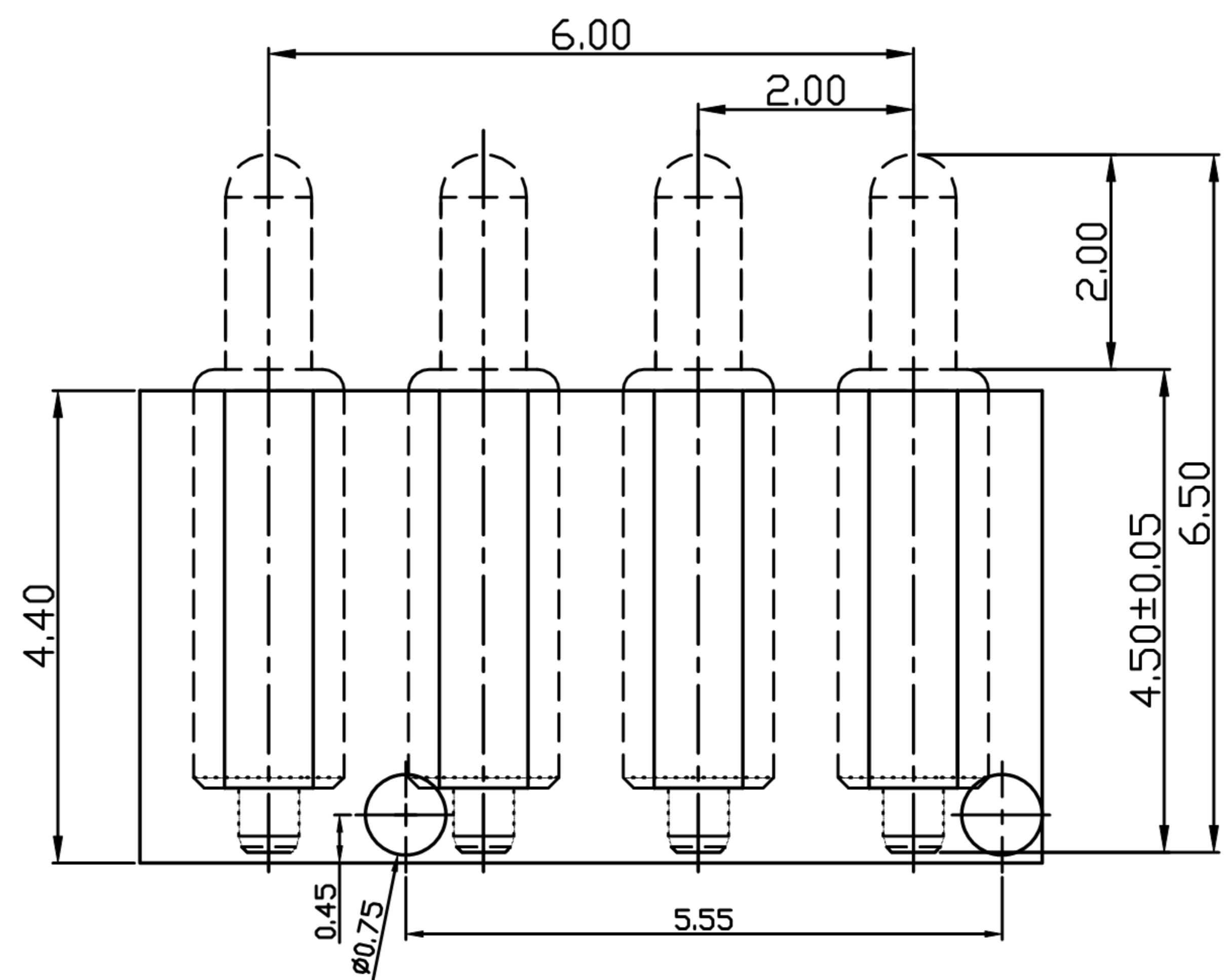

图为焊盘位置和大小

NOTE

1. Material
Plunger: Brass
Barrel: Brass
Spring: SUS
Housing: PA46
2. Plating
Plunger: Au over NI
Barrel: Au over NI
3. Electrical
Rated current & voltage: DC 12V; 2.0A Max.
4. Mechanical
Spring force: 60g±20% at normal working height
Durability: 10,000 cycles(minimum)
5. To ensure the best usage, please operate it based on the working height. Based on the engineering drawings, shall not exceed the maximum allowed compression.
6. To avoid arcing issue, The adaptor start to power supply after connector mated fully.

XB 东莞市溪榜电子有限公司
Switch Connector DONG GUAN XI BANG ELECTRONICS CO., LTD.

TOLERANCE UNLESS OTHERWISE STATED:
Up to 5 ±0.2
Above 5 ~ 15 ±0.3
Above 15 ~ 30 ±0.4
Above 30 ~ 50 ±0.5
Angle ±0.3°

3RD. ANGEL'S

UNITS MM

DRAWN BY:	DATE	MAT'L	TITLE	CONNECTOR
Jack Lu	04/01/21			
CHECKED BY:	DATE	FINISH	MODLE	POGO PIN
Jacky Chen	04/01/21			
APPROVED BY:	DATE	SCALE	DWG NO.	XB-PGC-X-200-4P-G
Tony Kao	04/01/21	1:1	PART NO.	Thimble Connector
SHEET NO.	1 of 1			

ITEM NO.	DESCRIPTION	DRAWN	DATE