

2MM

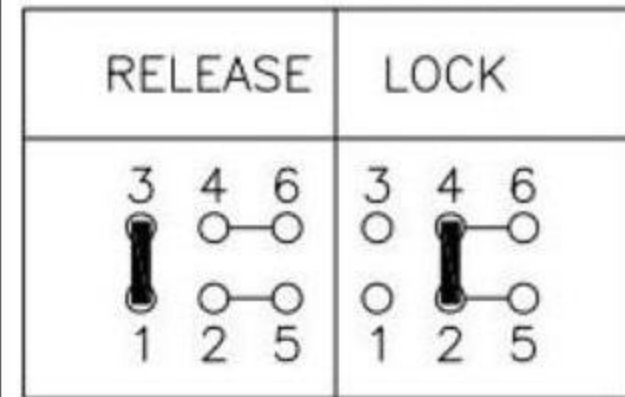

SCHEMATIC (NON-SHORTING)

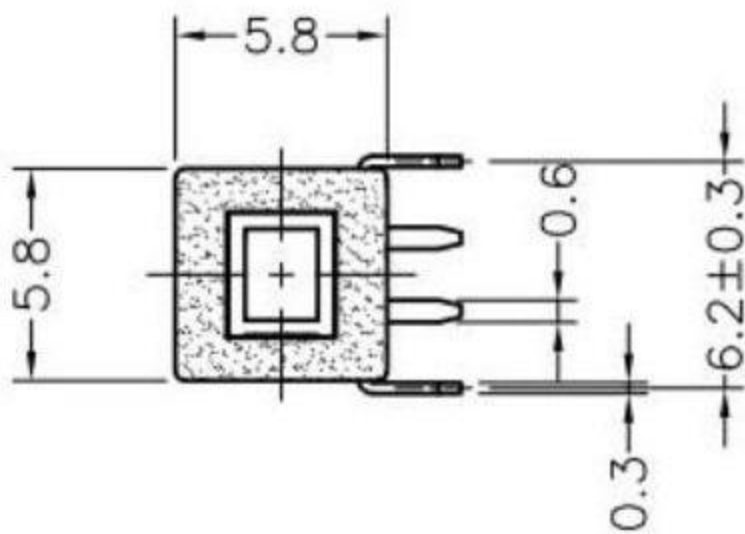
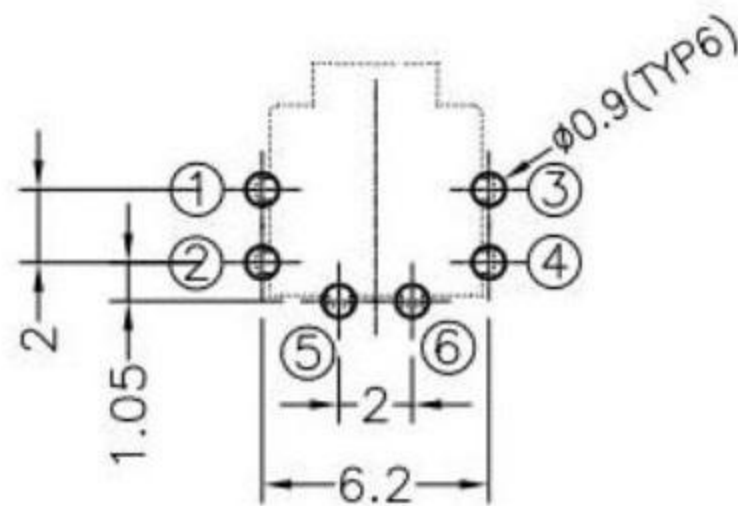
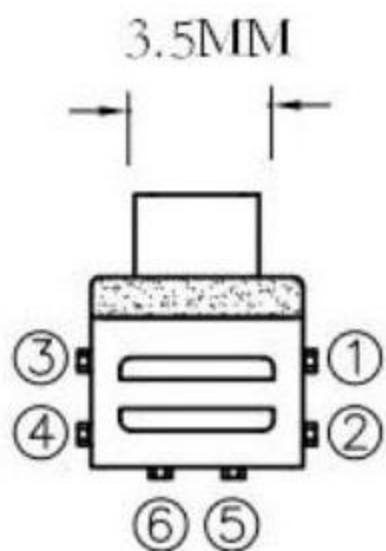

PCB LAYOUT

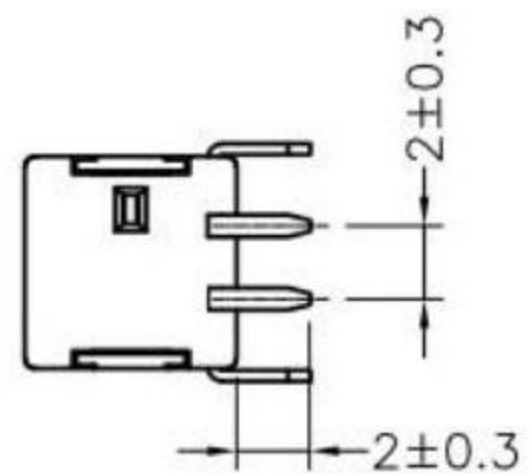

**SPECIFICATIONS**

- (1) LIFE TEST: 10000 cycles at a speed of 15-18 cycles
- (2) CONTACT RESISTANCE: 100mΩ max
- (3) INSULATION RESISTANCE: 100MΩ min
- (4) DIELECTRIC STRENGTH: 250V AC FOR 1MIN
- (5) OPERATING TEMPERATURE: -16°C - +60°C
- (6) RATING: 0.1A 30V DC
- (7) FUNCTION: 2P2T
- (8) TIMING: NON-SHORTING
- (9) OPERATING FORCE: 180gf ± 50gf

8					TOLERANCE UNLESS SPECIFIED				
7									
6					WITHIN 1.5mm : ±0.1mm	A	2016-10-14	初版	
5	SPRING	SUS304	1	NATURAL	OVER 1.5mm : ±0.2mm	ISSUE	DATE	DESCRIPTIONS OF REVISION	
4	CAM STICK	SUS304	1	NATURAL	TITLE : VERTICAL PUSH SWITCH		UNIT : mm	DRWG NO.:	
3	CASE	PA66/BRASS STRIP	1	GREY/Ag PLATED	MODEL:		SCALE: 5:1	DWN.	2016-10-14
2	COVER	PA66+15%F.G	1	BLACK	东莞市溪榜电子有限公司		CHK'D		2016-10-14
1	KNOB	PA66+15%F.G/PBS STRIP	1	BLACK/Ag CLAD			APPD.		
NO.	PARTS	MATERIALS	Q'TY						