

REV NO/版次	REVISION NOTE/修订注释	DATE/日期	SIGNATURE/签名

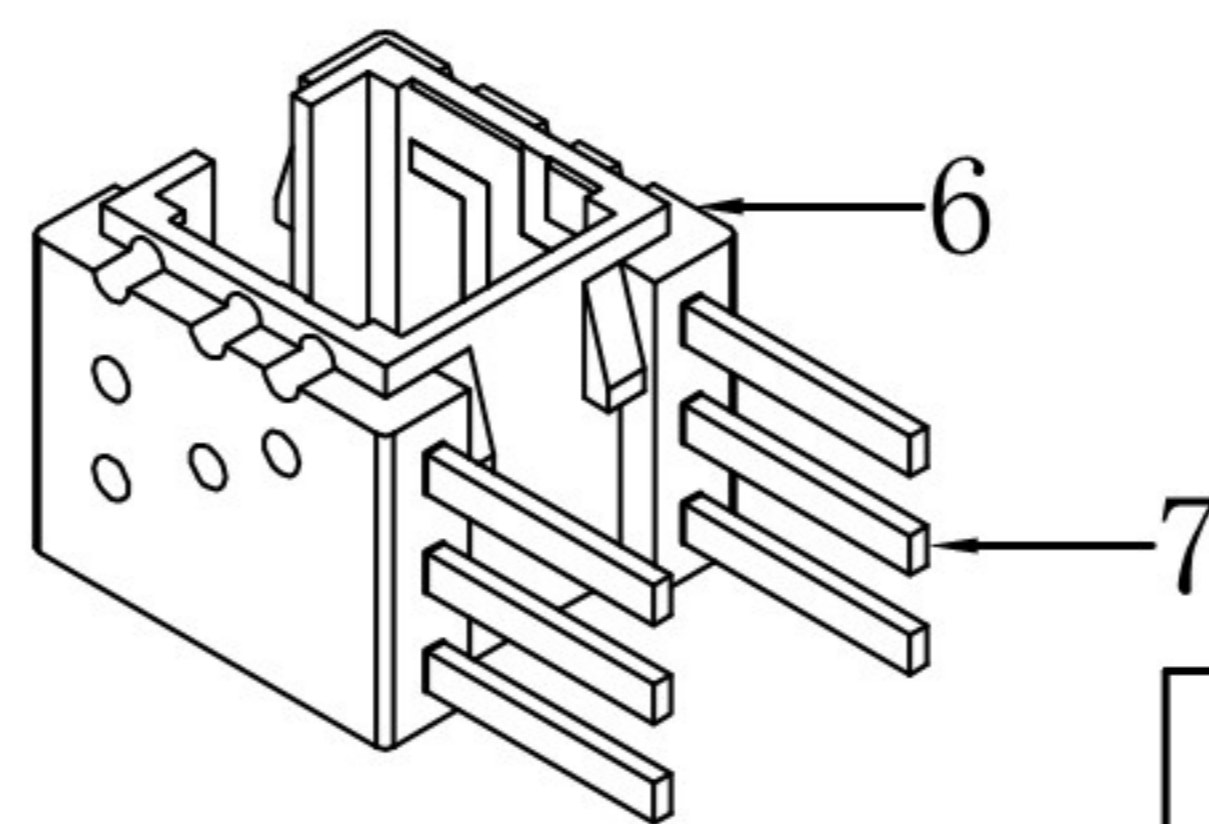
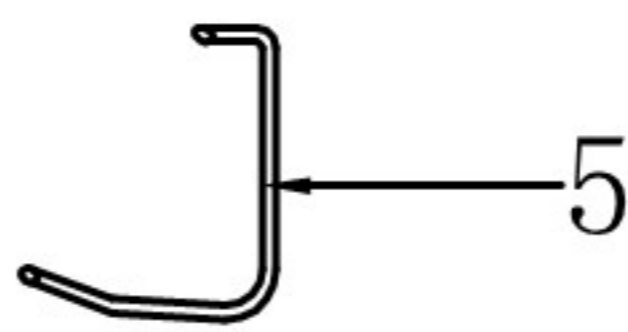
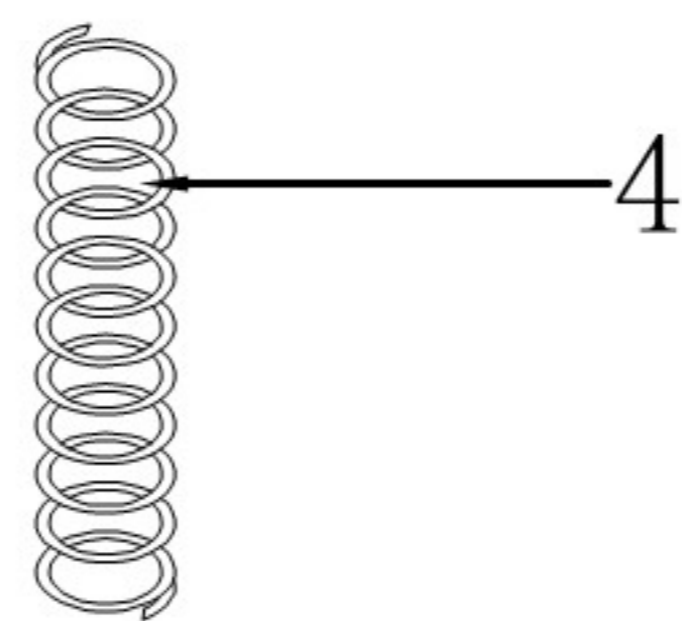
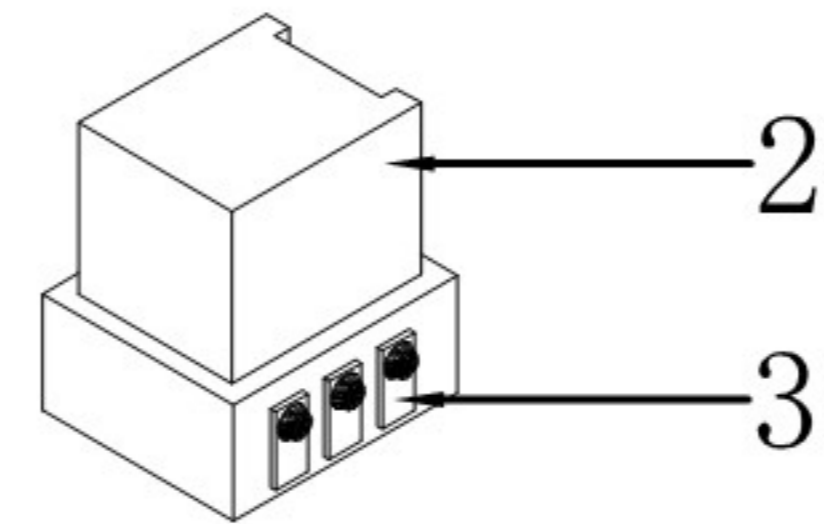
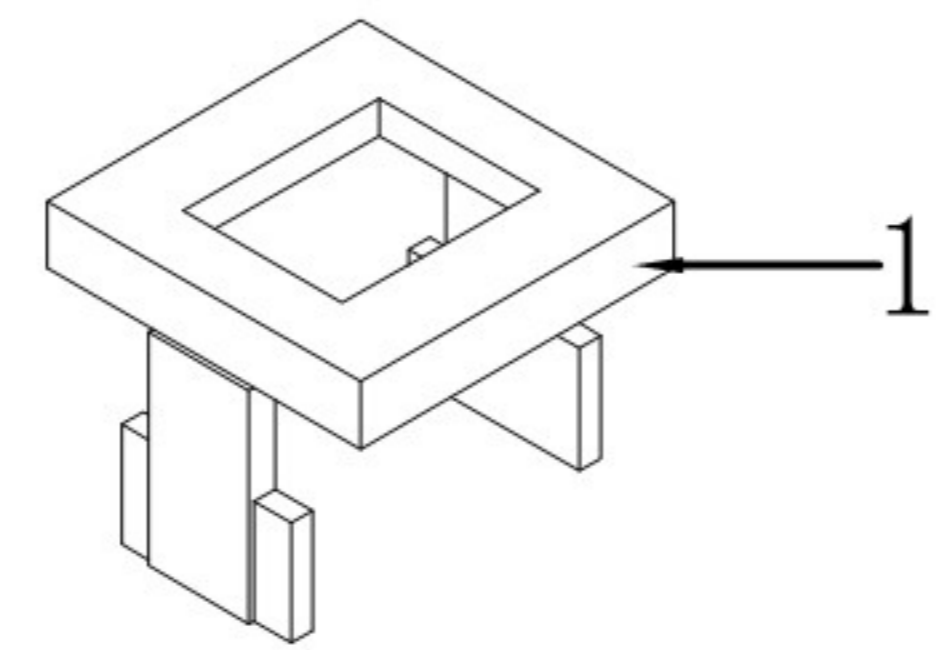
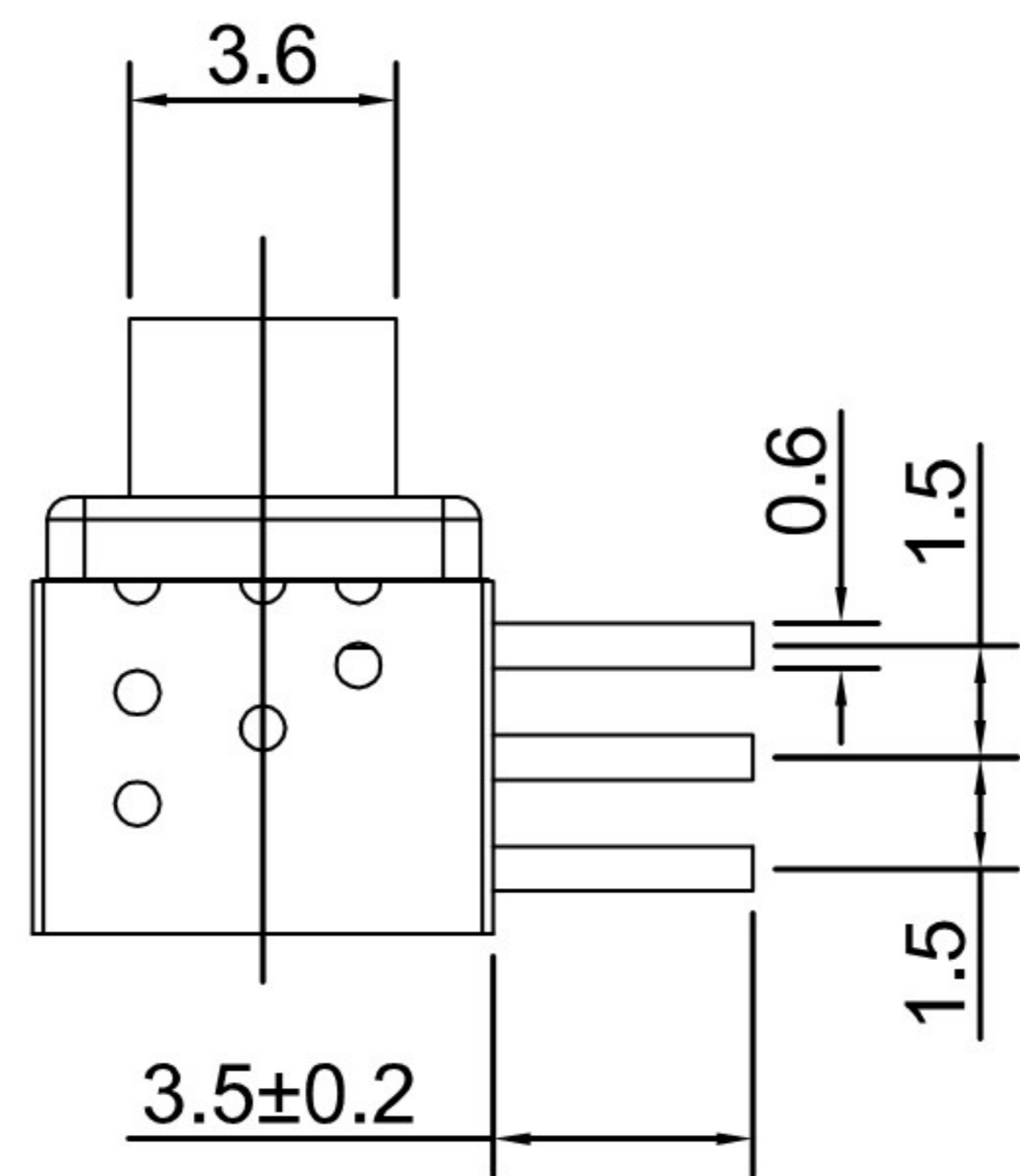
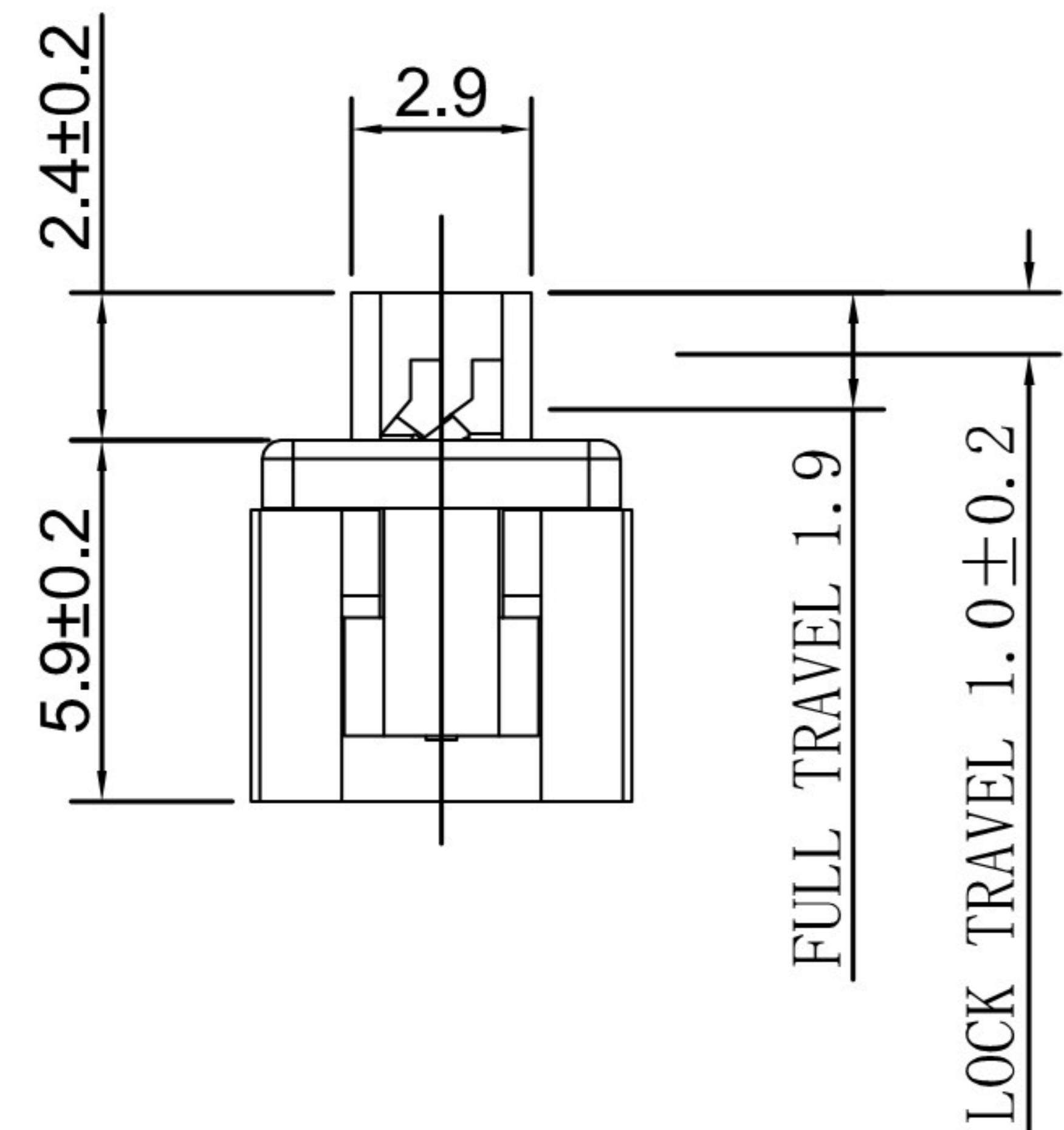
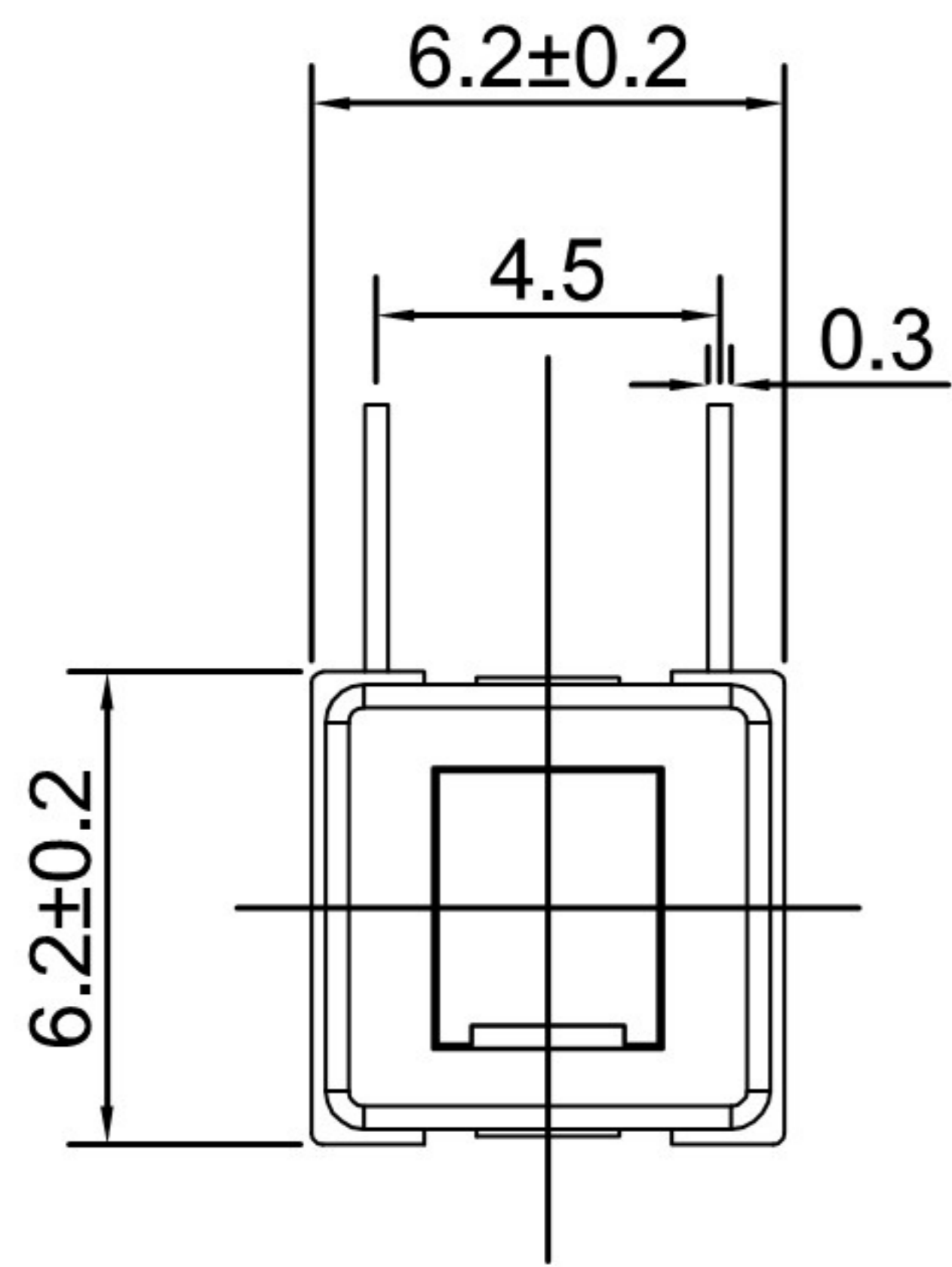

### ELECTRICAL CHARACTERISTICS

1. RATING: DC 30V 0.5A
2. CONTACT RESISTANCE: 100mΩ MAX
3. INSULATION RESISTANCE: 100MΩ MIN
4. DIELECTRIC STRENGTH: AC 250V (50~60Hz)/60S

### MECHANICAL CHARACTERISTICS

1. PRACTICAL TEMPERATURE RANG: -40℃~+85℃
2. OPERATING FORCE: 180±30gf
3. MECHANICAL LIFE: 10,000 cycles

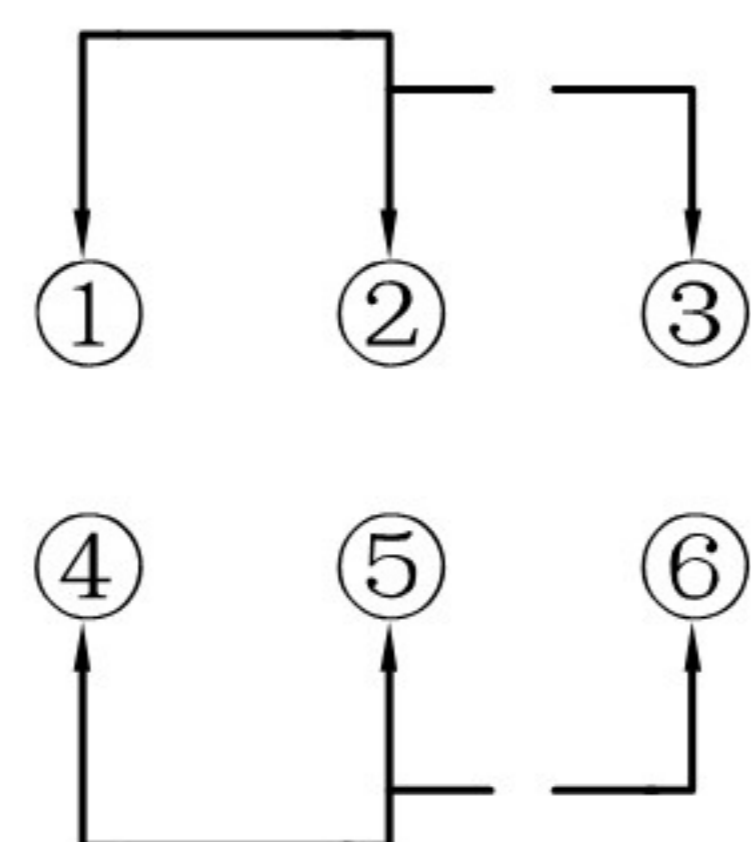
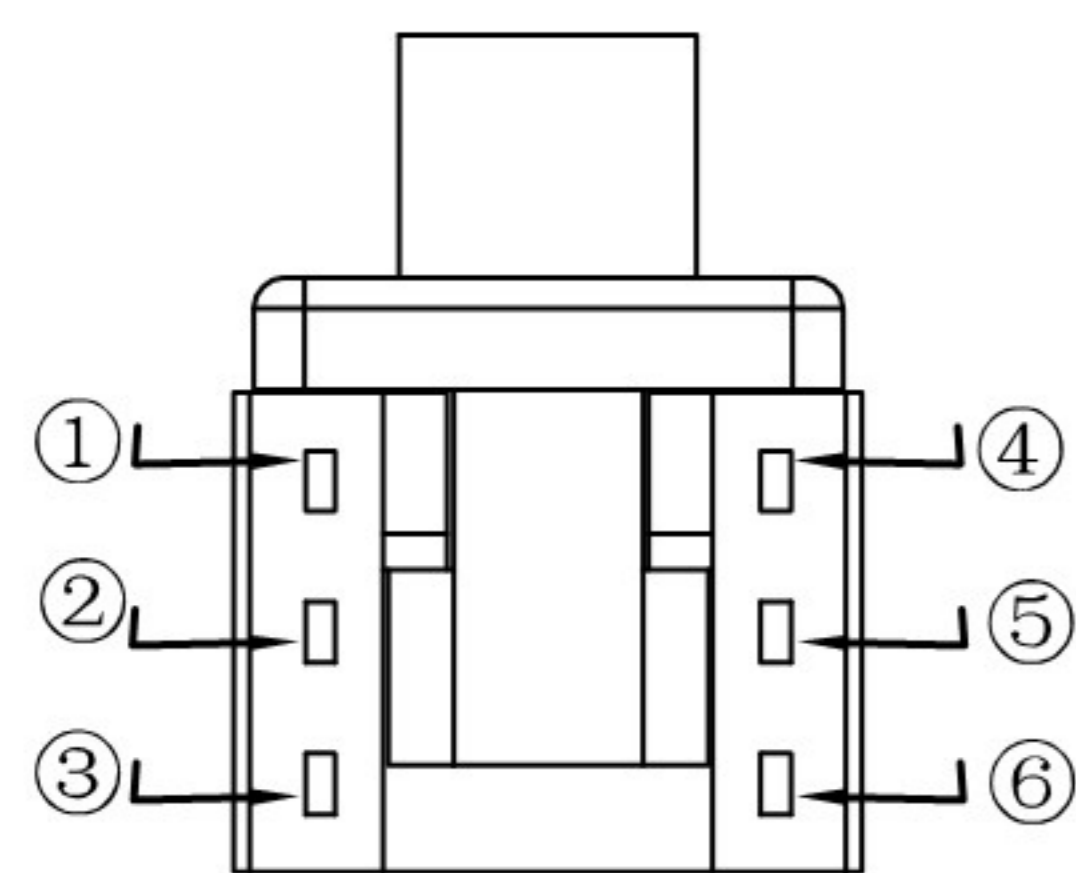

SCHEMATIC

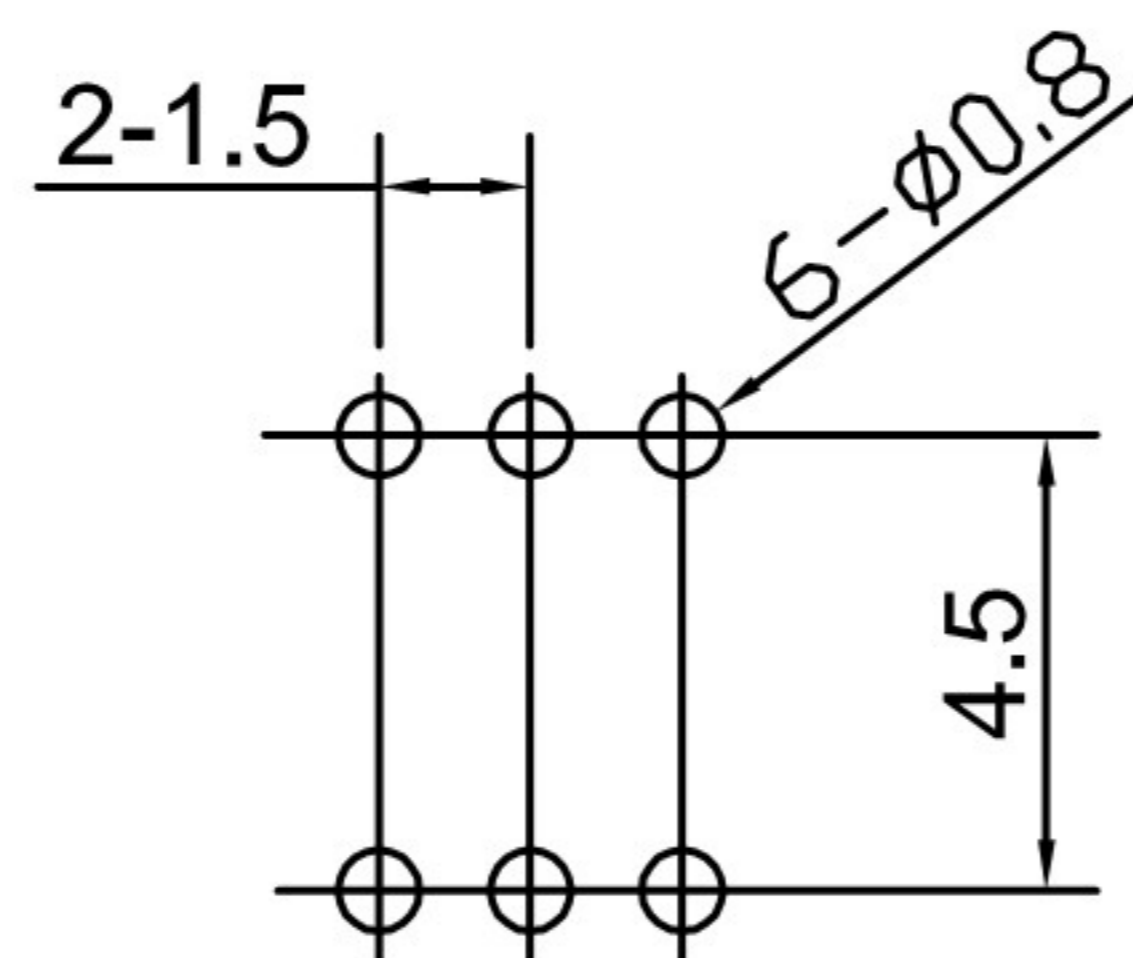

P. C. B LAYOUT

7	TERMINAL	BRASS	6	Ag PLATED
6	CASE	PA66	1	GRAY
5	LOCK PIN	SUS WIRE $\phi 0.35$	1	NATURAL
4	SPRING	SUS WIRE	1	NATURAL
3	CONTACT	BRONZE	2	Ag PLATED
2	KNOB	PBT	1	WHITE
1	COVER	PA66	1	BLACK
NO.	PART NAME	MATERIAL	QTY.	FINISHING

**XB** 东莞市溪榜电子有限公司  
DONG GUAN XI BANG ELECTRONICS CO., LTD.

GENERAL TOLERANCE未指的公差		TITLE	
X. ± 0.5	X. ° ± 5°	名称 XB-5858-X-P	
.X ± 0.3	.X ° ± 2°	PART NO. 零件编号	
.XX ± 0.2	.XX ° ± 1°	DWG NO. 图纸编号	
.XXX ± 0.1	.XXX ° ± 0.5°	XB-5858-X-P	
APPROVAL 审批	CHECKED 核准	DRAWN 设计	UNIT 单位 (mm)
			SCALE 比例
			1:1
			PROJ.
			REV.