

# ROHS

REV.	ECN. NO.	APPD.

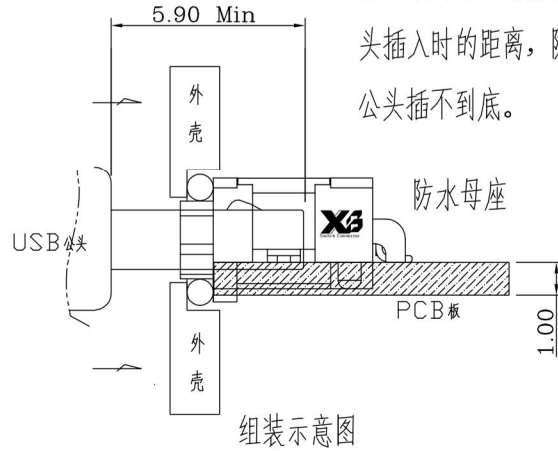

注：设计时，请注意公头插入时的距离，防止公头插不到位。

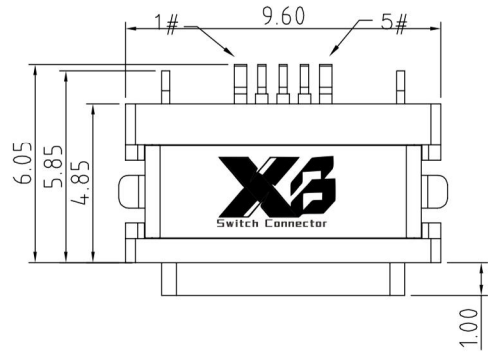
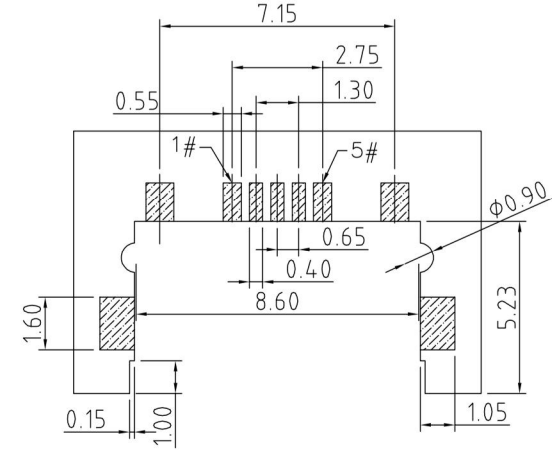

RECOMMENDED PCB LAYOUT(TOP VIEW)

THICKNESS T=1.0mm  
DEFAULT TOLERANCE+/-0.05

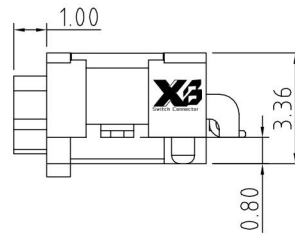
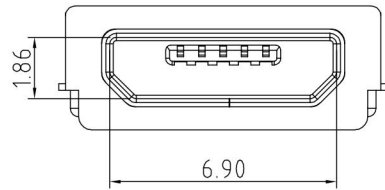

SPECIFICATIONS:

- ELECTRICAL CHARACTERISTICS:
  - RATING: 3A(PIN1&5),0.5A(PIN2&3&4);
  - CONTACT RESISTANCE: 30 mΩ MAX.(INITIAL);
  - DIELECTRIC WITHSTANDING: 500V AC MIN.;
  - INSULATION RESISTANCE: 1000MΩ MIN.;
- DURABILITY: 5,000 CYCLES MIN.;
- INSERTION FORCE: 3.5Kgf (35N) Max.;
- EXTRACTION FORCE: 0.8Kgf (8N) Min.;
- WATER PROOFNESS: THIS PRODUCT IS BASED ON IPX8
- PLUG INTERFACE DIMENSIONS COMFORM TO USB2.0 SPEC.
- PACKAGING: TAPE & REEL.

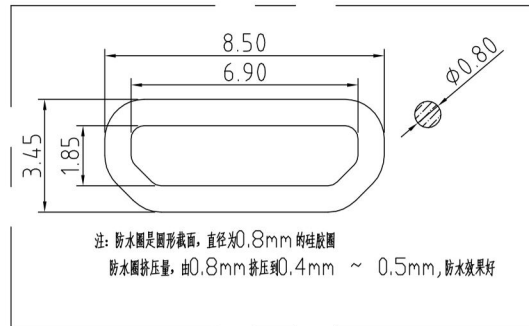
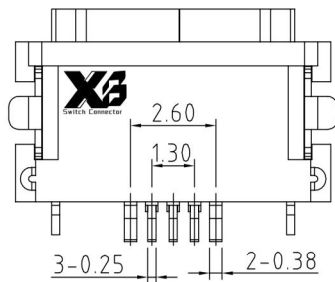

注：防水圈是圆形截面，直径为0.8mm的硅胶圈  
防水圈挤压力，由0.8mm挤压力0.4mm ~ 0.5mm，防水效果好

Contact Number	Signal Name	Remarks
1#	VBUS	Power
2#	D-	Date-
3#	D+	Date+
4#	ID	Reserve or Gound
5#	GND	Gound

3	Shell	1	SUS304R-1/2H Ni PlatingT=0.25mm	
2	Contact	5	Phosphor bronze_C5191R-EH Au/Ni Plating T=0.20mm	
1	Housing	1	PA10T (G.F30%)	
ITEM	PARTNAME	Q'TY	FINISH	NOTE
X.	±0.50	X.* ±2°	UNITS mm	<b>东莞市溪榜电子有限公司</b> <b>DONG GUAN XI BANG ELECTRONICS CO., LTD</b>
.X	±0.30	.X* ±1°		
.XX	±0.10	.XX* ±0.5°	MAT'L	
.XXX	±0.05		FINISH	
			Q'TY	
			PART NO.	TITLE:
			XB-USB-M-5P-1198-IPX7	Micro USB 5Pin SMT (B) Type (深0.8,全翻)
			APPD: GAO. PENG	DWG NO.:
			CHKD: HE. LONG. FEI	
			DR: PANG. DONG	
				SCALE SHEET REV.
				1/1 1/1 A1