

ROHS

REV.	ECN. NO.	APPD.

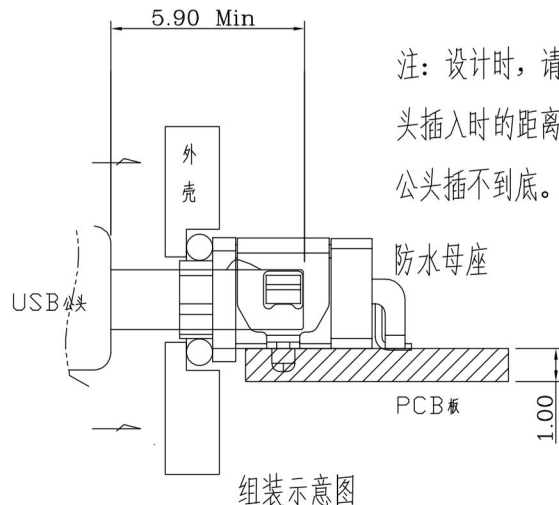
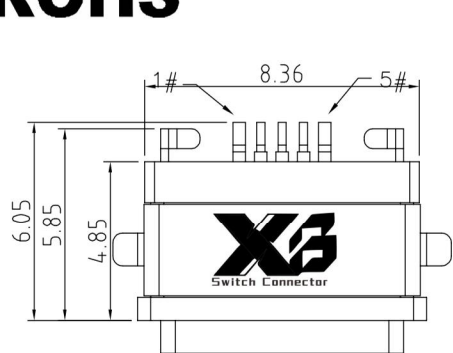

注：设计时，请注意公头插入时的距离，防止公头插不到底。

组装示意图

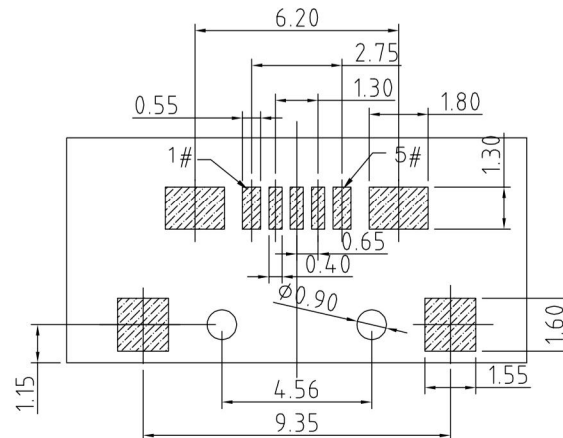

RECOMMENDED PCB LAYOUT(TOP VIEW)

THICKNESS T=1.0mm
DEFAULT TOLERANCE+/-0.05

SPECIFICATIONS:

- ELECTRICAL CHARACTERISTICS:
 - RATING: 3A(PIN1&5),0.5A(PIN2&3&4);
 - CONTACT RESISTANCE: 30 mΩ MAX.(INITIAL);
 - DIELECTRIC WITHSTANDING: 500V AC MIN.;
 - INSULATION RESISTANCE: 1000MΩ MIN.;
- DURABILITY: 5,000 CYCLES MIN.;
- INSERTION FORCE: 3.5Kgf (35N) Max.;
- EXTRACTION FORCE: 0.8Kgf (8N) Min.;
- WATER PROOFNESS: THIS PRODUCT IS BASED ON IPX8
- PLUG INTERFACE DIMENSIONS COMFORM TO USB2.0 SPEC.
- PACKAGING: TAPE & REEL.

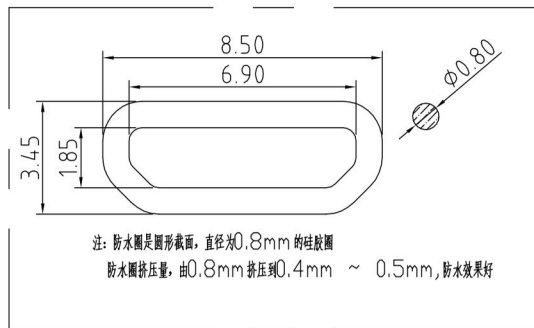
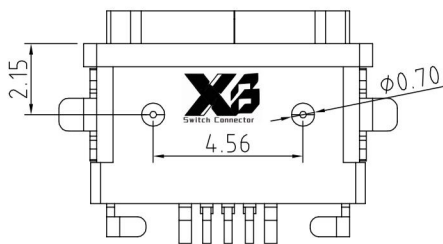
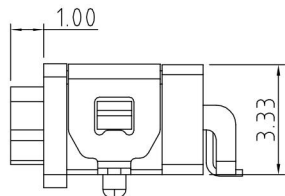
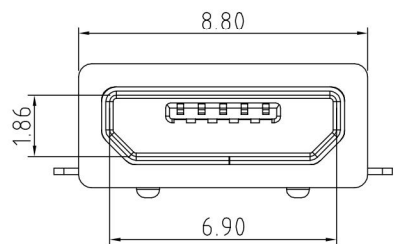

注：防水圈是圆形截面，直径为0.8mm的硅胶圈
防水圈挤压力，由0.8mm挤压力0.4mm ~ 0.5mm，防水效果好

Contact Number	Signal Name	Remarks
1#	VBUS	Power
2#	D-	Date-
3#	D+	Date+
4#	ID	Reserve or Gound
5#	GND	Gound

3	Shell	1	SUS304R-1/2H Ni Plating T=0.25mm	
2	Contact	5	Phosphor bronze C5191R-EH Au/Ni Plating T=0.20mm	
1	Housing	1	PA10T (G.F30%)	
ITEM	PARTNAME	Q'TY	FINISH	NOTE

X.	±0.50	X.*	± 2°	UNITS mm	东莞市溪榜电子有限公司 DONG GUAN XI BANG ELECTRONICS CO., LTD
.X	±0.30	.X*	± 1°		
.XX	±0.10	.XX*	± 0.5°	MAT'L /	PART NO. XB-USB-M-5P-1197S-IPX7
.XXX	± 0.05				
				FINISH /	TITLE: Micro USB 5Pin SMT (B) Type (贴片)
					APPD: GAO. PENG
				Q'TY /	CHKD: HE. LONG. FEI
					DR: PANG. DONG

	SCALE	SHEET	REV.
	1/1	1/1	A1