

ROHS

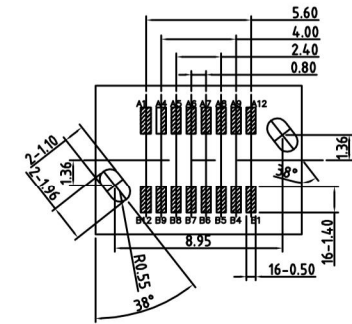

REV.	ECN. NO.	APPD.

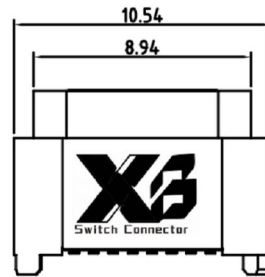
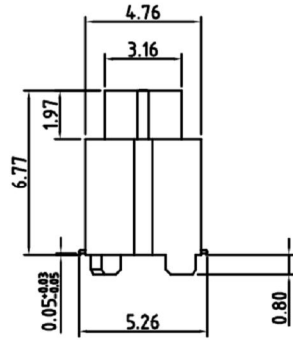
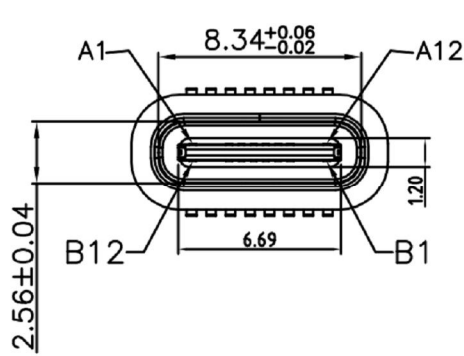

RECOMMENDED PCB LAYOUT(TOP VIEW)

THICKNESS T=1.0mm
DEFAULT TOLERANCE+/-0.05

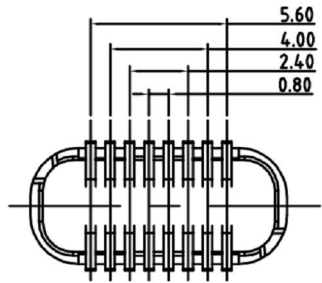

INTERFACE(FRONT VIEW)

A1	A2	A3	A4	A5	A6	A7	A8	A9	A10	A11	A12
GND			VBUS	CC1	DP1	DN1	SBU1	VBUS			GND
GND			VBUS	SBU2	DN2	DP2	CC2	VBUS			GND
B12	B11	B10	B9	B8	B7	B6	B5	B4	B3	B2	B1

PIN ASSIGNMENT

PIN NO.	A1&B12	A4&B9	B8	A5	B7	A6	A7	B6	A8	B5	A9&B4	A12&B1
SINGAL NAME	GND	VBUS	SBU2	CC1	DN2	DP1	DN1	DP2	SBU1	CC2	VBUS	GND
PCB PAD NO.	C1	C2	C3	C4	C5	C6	C7	C8	C9	C10	C11	C12

NOTES:

- MATERIAL: SEE "TABLE 1";
- FINISH: SEE "TABLE 1";
- ELECTRICAL :
 - 3-1.CONTACT CURRENT RATING : 5A(VBUS PIN 1.5A/PIN), 5A(GND PIN 1.25A/PIN MAX),0.25A/PIN(OTHER PIN).
 - 3-2.INSULATION RESISTANCE : 100 MEGAOHMS MIN. AT 250VDC.
 - 3-3.DIELECTRIC WITHSTANDING VOLTAGE : 100VAC MIN.
 - 3-4.LOW LEVEL CONTACT RESISTANCE : INITIAL 40mΩ MAX. AFTER 50mΩ MAX.
- MECHANICAL CHARACTERISTICS :
 - 4-1. MATING FORCE: 5~20N.;
 - 4-2. UNMATING FORCE: 8~20N(INITIAL),6~20N(AFTER 10000 CYCLES);
 - 4-3.DURABILITY : 10,000 MATING CYCLES.
 - 4-4.OPERATING TEMPERATURE :-40°C TO +80°C

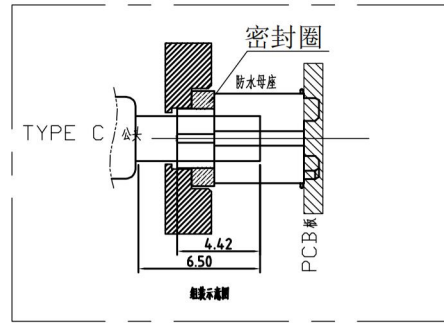
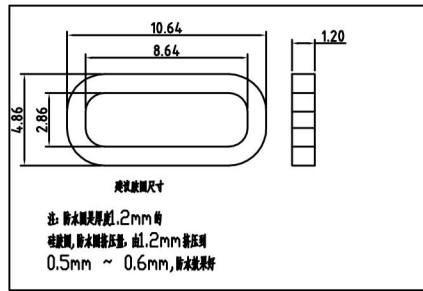

TABLE 1:

⑤	Shell-1	1	Stainless steel	NI PLATING;	T=0.30mm
④	MID PLATE	1	Stainless steel		T=0.15mm
③	Terminal-B	8	铜镍硅合金	Au:3u* PLATING;	T=0.15mm
②	Terminal-A	8	铜镍硅合金	Au:3u* PLATING;	T=0.15mm
①	Housing	1	HIGH TEMP	Black	
NO.	PART NAME	QTY	MATERIAL	DESCRIPTION	REMARK

X.	±0.50	X.*	± 2°	UNITS	mm
.X	±0.30	.X.*	± 1°		
.XX	±0.10	.XX.*	± 0.5°	MAT'L	
.XXX	± 0.05				

THESE DRAWINGS AND SPECIFICATIONS ARE THE PROPERTY OF XI BANG ELECTRONIC TECHNOLOGY CO., LTD. AND SHALL NOT BE REPRODUCED, COPIED OR USED IN ANY MANNER WITHOUT THE PRIOR WRITTEN CONSENT OF XI BANG ELECTRONIC TECHNOLOGY CO., LTD

东莞市溪榜电子有限公司 DONG GUAN XI BANG ELECTRONICS CO., LTD			
PART NO.	XB-USB-C-16P-1143N-IPX7	TITLE:	TYPE C 16Pin SMT 防水连接器
APPD:	GAO. PENG	DWG NO.:	XB-USB-C-16P-1143N-IPX7
CHKD:	HE. LONG. FEI	SCALE	SHEET
DR:	PANG. DONG	1/1	1/2

