



XB-MSK-006M-U

Model No.	X (mm)
Blank	2.0
A	4.0

SLIDER COLOR :

Black : B

White : W

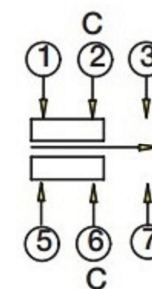
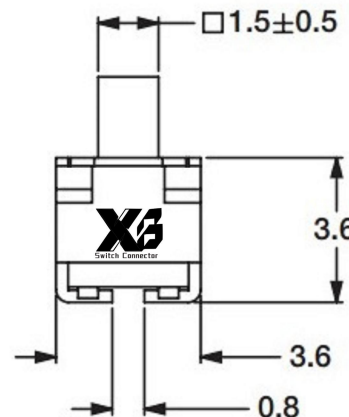
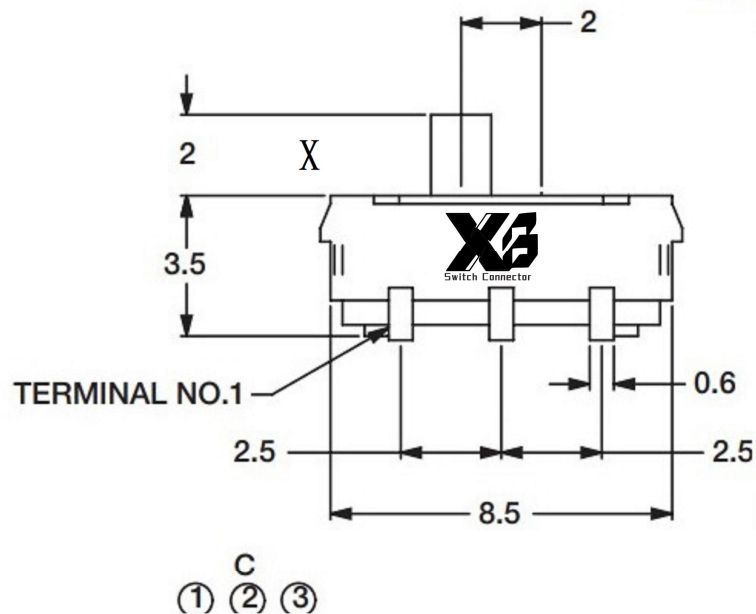

CIRCUIT DIAGRAM
C: COMMON PIN
BOTTOM VIEW

CIRCUIT DIAGRAM

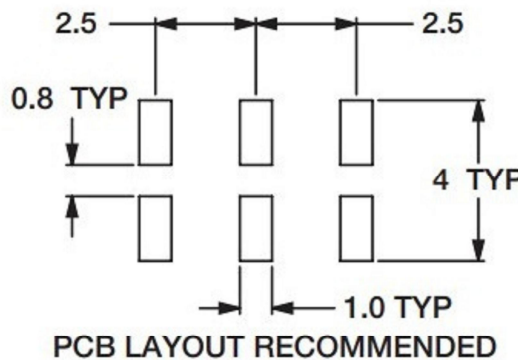
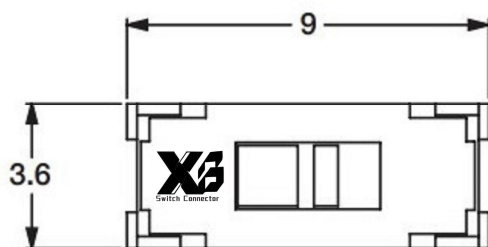

SPECIFICATIONS

Rating	100mA , 12V DC
Insulation Resistance	100MΩ Min.
Dielectric Withstanding Voltage	AC 250 V(50Hz)1min
Contact Resistance	100mΩ Max.
Operating Force	200 ± 70gf
Operating Life	10,000 cycles

NO.	DESCRIPTION	QTY	MATERIAL	PLATING
E	TERMINAL	3	PHOSPHOR BRONZE	Ag plated
D	CLIP	2	PHOSPHOR BRONZE	Ag plated
C	COVER	1	SUS	
B	BASE	1	PA	Black
A	SLIDER	1	PA	Black

MAT'L		TITLE	SWITCH
FINISH		MODLE	SLIDE SWICTH
SCALE	1 : 1	DWG. NO.	XB-MSK-006M-U
SHEET NO.	1 of 1	PART NO.	

XB 东莞市溪榜电子有限公司
DONG GUAN XI BANG ELECTRONI CS CO., LTD.

TOLERANCE UNLESS OTHERWISE STATED :
Up to 5 ±0.2
Above 5 ~ 15 ±0.3
Above 15 ~ 30 ±0.4
Above 30 ~ 50 ±0.5
Angle ±0.3

3RD. ANGEL'S

UNITS MM

DRAWN BY: Jack Lu DATE: 09/09/21
CHECKED BY: Jacky Chen DATE: 09/09/21
APPROVED BY: Tony Kao DATE: 09/09/21

ITEM NO. DESCRIPTION DRAWN DATE

SIZE A4
VER R



XB-MSK-006M-U

Model No.	X (mm)
Blank	2.0
A	4.0

SLIDER COLOR :

Black : B
White : W

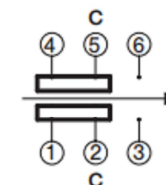
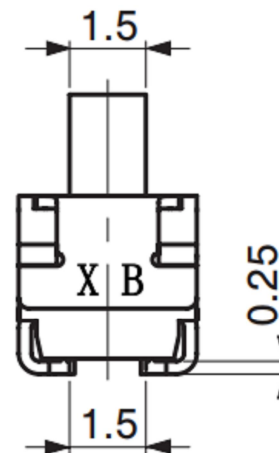
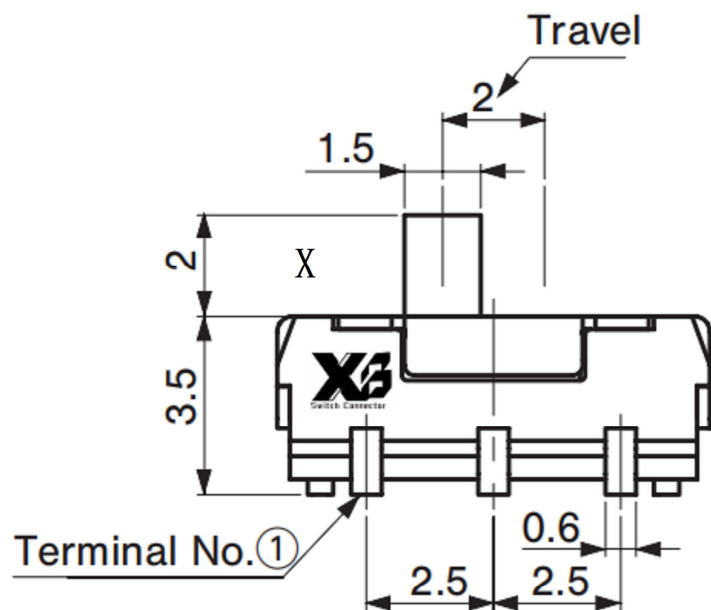

CIRCUIT DIAGRAM

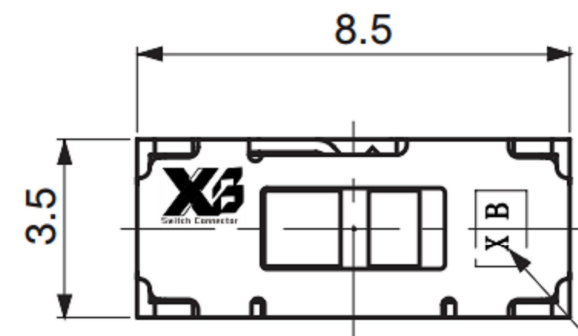

Production date code

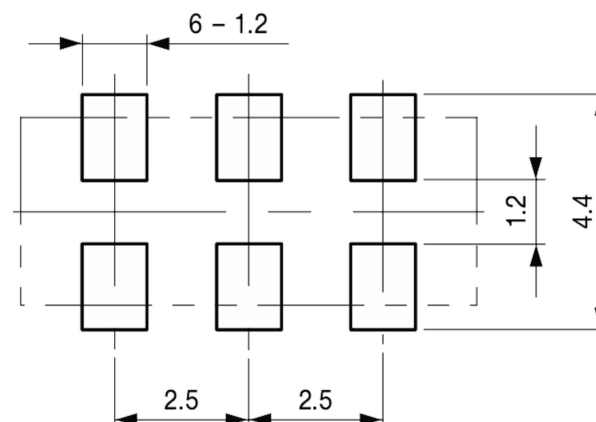

P.C.B LAND PATTERN

SPECIFICATIONS

Rating	100mA , 12V DC
Insulation Resistance	100MΩ Min.
Dielectric Withstanding Voltage	AC 250 V(50Hz)1min
Contact Resistance	100mΩ Max.
Operating Force	200 ± 70gf
Operating Life	10,000 cycles

NO.	DESCRIPTION	QTY	MATERIAL	PLATING
E	TERMINAL	3	PHOSPHOR BRONZE	Ag plated
D	CLIP	2	PHOSPHOR BRONZE	Ag plated
C	COVER	1	SUS	
B	BASE	1	PA	Black
A	SLIDER	1	PA	Black

MAT'L	TITLE	SWITCH
FINISH	MODLE	SLIDE SWICTH
SCALE	1 : 1	DWG NO. XB-MSK-006M-U
SHEET NO.	1 of 1	PART NO.

XB 东莞市溪榜电子有限公司
DONG GUAN XI BANG ELECTRONICS CO., LTD.

TOLERANCE UNLESS OTHERWISE STATED :
Up to 5 ±0.2
Above 5 ~ 15 ±0.3
Above 15 ~ 30 ±0.4
Above 30 ~ 50 ±0.5
Angle ±0.3

3RD. ANGEL'S

UNITS MM

DRAWN BY: Jack Lu DATE: 09/09/21
CHECKED BY: Jacky Chen DATE: 09/09/21
APPROVED BY: Tony Kao DATE: 09/09/21

ITEM NO.	DESCRIPTION	DRAWN	DATE