

PCB LAYOUT

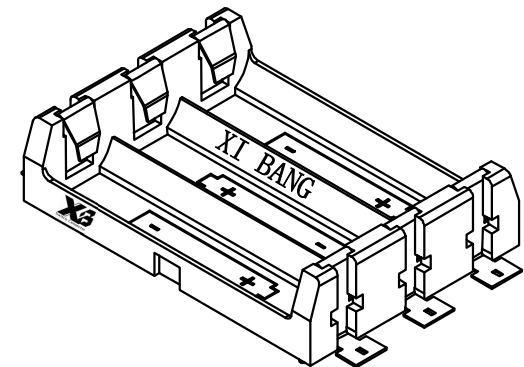

NOTE:

- * Type: Surface Mounted Device (SMT)
- * Base Material: High Temp Nylon+30%GF Black Color
- * Flammability Rating: UL94V-0
- * Contacts: 0.35mm Stainless Steel Temper, Flash Gold
- * Dielectric Strength: 560 Volts/Mil. at 25°C for 5 Sec.
- * RoHS COMPLIANT

 东莞市溪榜电子有限公司 Switch Connector DONG GUAN XI BANG ELECTRONICS CO., LTD			
PART NAME			
THREE "AA" CELLS HOLDER			
PROJECTIVE 	TOLERANCES [MM]	DRN BY Gao. Peng	DATE 2020 04 15
	DECIMAL [±.10]	APPD Pang. Dong	SCALE 1X
	ANGULAR ±0.50°	DWG NO. XB-BC-PA-331-SMT	CODE AA
UNLESS OTHERWISE SPECIFIED			