

- NOTES.
- MATERIAL SEE TABLE;
 - PLATING SEE TABLE;
 - RATING
 - OPERATING TEMPERATURE: -40~105°C
 - OPERATING VOLTAGE: 100V AC/DC
 - CURRENT RATING: 1.0 AMPS
 - DIELECTRIC WITHSTANDING VLTAGE: 500V AC/Minute;
 - INSULATION RESISTANCE: 500MΩ Min;
 - CONTACT RESISTANCE: 0.03Ω Max;

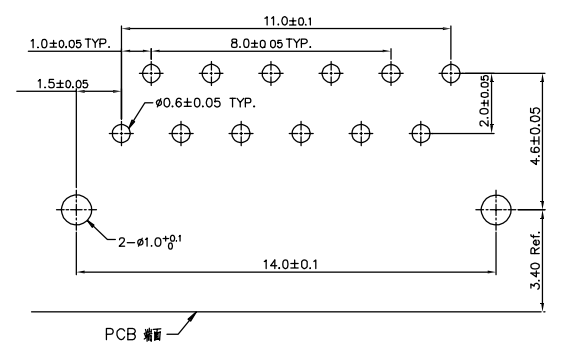
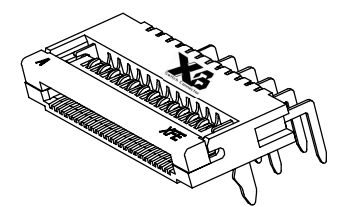
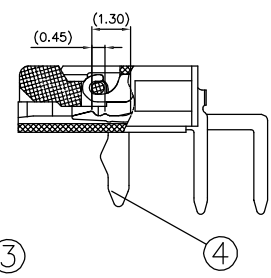
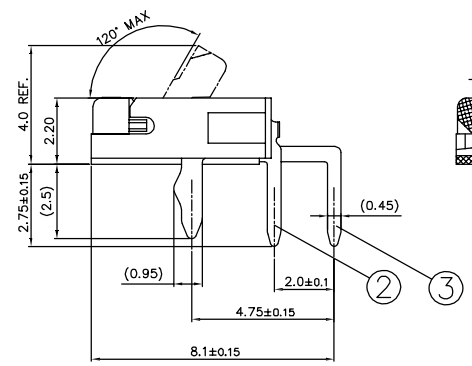
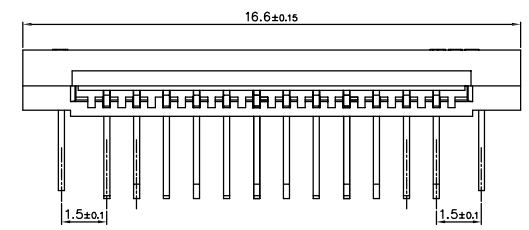

Ordering Information

126 - XX XX A 001 C X S X-06

No. of Pins per Row: 12
 Standard Plating: 02=Gold Flash, Selective Plating, 01=Tin
 Color: 2=White, 1=Black
 Standard Packing: C=Tube, Selective Packing: D=Tape&Reel

5	物 Actuator	LCP (UL94V-0)	1	黑色
4	料 Fitting Nail	磷磷 Phosphor Bronze	2	鍍金 鍍金厚度≥30u"MIN, 磷磷≥30u"MIN.
3	料 B Contact	磷磷 Phosphor Bronze	6	鍍金 鍍金厚度≥30u"MIN, 磷磷GOLD FLASH..
2	料 A Contact	磷磷 Phosphor Bronze	6	鍍金 鍍金厚度≥30u"MIN, 磷磷GOLD FLASH..
1	殼 Housing	LCP (UL94V-0)	1	棕色
序号	名称	材料	数量	备注

XB 东莞市溪榜电子有限公司
 DONG GUAN XI BANG ELECTRONICS CO., LTD

GENERAL TOLERANCE	
X.*±3.0"	X.±
.X*±0.5"	.X±0.25
.XX*±	.XX±0.15
.XXX*±	.XXX±0.05

DESIGNED:
 CHECKED:
 APPROVED:

DATE:
 DATE:
 DATE:

DWG. NO.
XB-FPC-10-126
 PART NO.

TITLE:
 1.0 FPC CONN. NON ZIF DIP
 FRONTAFLIP H=3.5 CONTACT