

Specifications  
 Current Rating:3.0AmpAC/DC  
 Voltage rating:250V AC/DC  
 Insulation Resistance:1000MΩMin.  
 Dielectric Withstanding Voltage:1000VAC  
 Contact Resistance:30mΩMax.  
 Operating Temperature:-25°C to +85°C  
 Materials  
 Contact Material:Phosphor Bronze  
 Stabilizer Material:Brass  
 Insulator Material:Thermoplastic, UL 94V-0  
 PBT or the equivalent material  
 All materials must meet XI BANG  
 hazardous substances control standards.

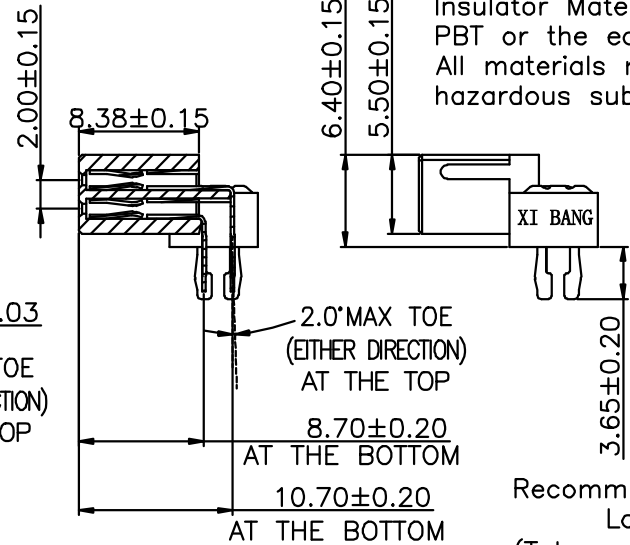

Recommended P.C.Board  
 Layout  
 (Tolerance:±0.05)

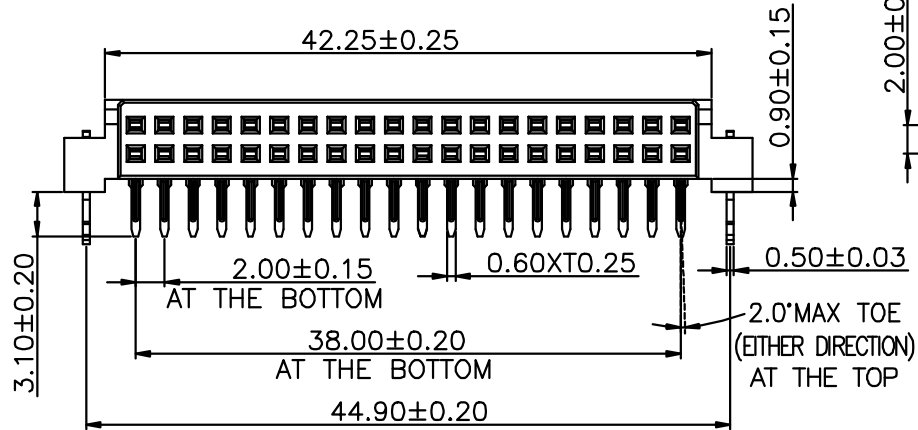
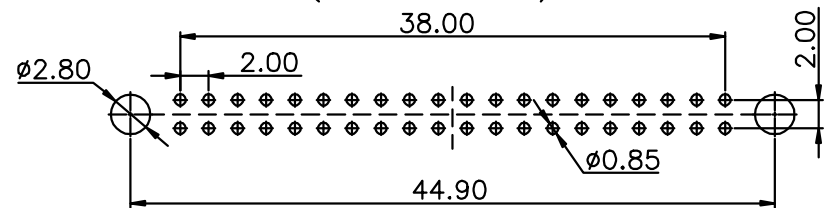

### Ordering Information

**XB-X20-PCB-201**

No. of Pins per Row: 20  
 Standard Plating: 01=Ni: 50~100u", Tin80~160u"  
 Color: K=White, X=Black  
 Standard Packing: S=Standard, X=Tube

<b>东莞市溪榜电子有限公司</b> DONG GUAN XI BANG ELECTRONICS CO., LTD	GENERAL TOLERANCE		DESIGN:	DATE:	DWG. NO.	TITLE.
	X.*±5.0'	X.±0.30	CHECKED:	DATE:	XB-X20-PCB-201	
	.X'±3.0'	.X±0.25	CO SIGNED:	DATE:	PART NO.	2.00mm Pitch Connector
	.XX'±2.0'	.XX±0.15	APPROVED:	DATE:		
REV. A	UNIT. mm	SCALE. 2:1	PAGE. 1/1			